

DATA SHEET

VT 4.16

ROTARY VANE VACUUM PUMPS

oil-free

air-cooled

MAKE IT BECKER.



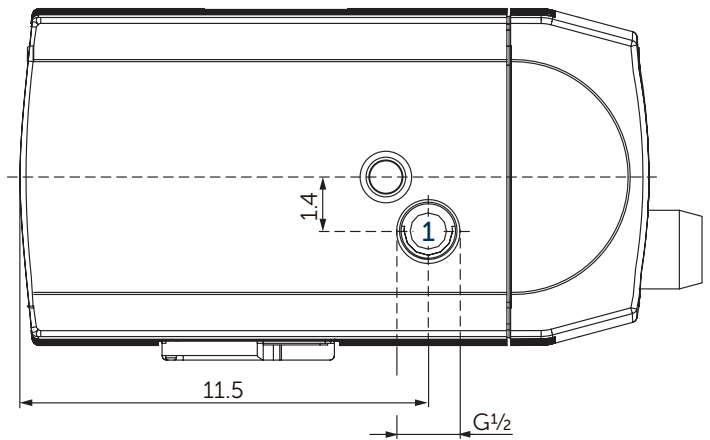
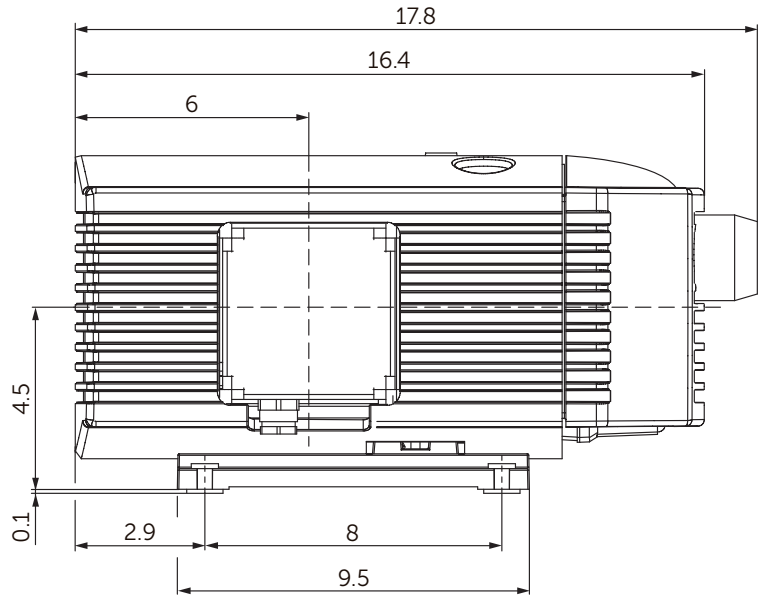
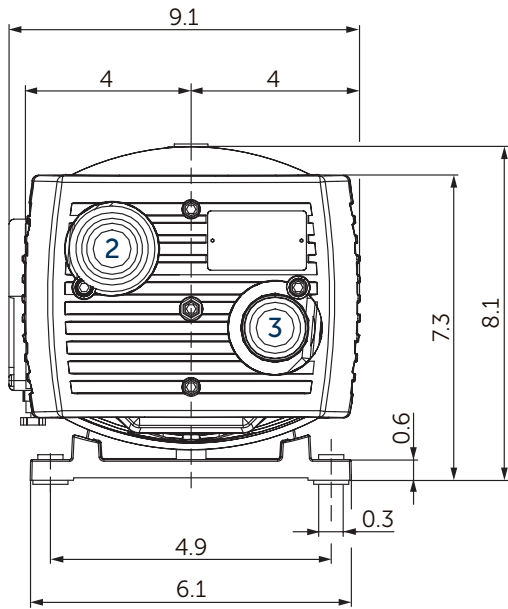

- 1 Vacuum connection (G $\frac{1}{2}$)
- 2 Vacuum regulating valve
- 3 Blow-off valve
- Including integrated suction air filter
- Dimensions in inch

Suction air rate		Vacuum		Motors 3~		Emission sound pressure level ¹⁾		Weight with motor
CFM		Torr	in. HgV	hp		dB(A)		lbs
50 Hz	60 Hz	50 & 60 Hz	50 & 60 Hz	50 Hz	60 Hz	50 Hz	60 Hz	
9.4	11.2	112.5	25.4	0.7	0.9	61	64	≈49.6 ²⁾

¹⁾ According to DIN EN ISO 3744 (KpA = 3 dB(A)), 39.4 inch distance, at medium load, both connection sides piped

²⁾ Depending on the motor

3~ Motors									
#	50 Hz				60 Hz				Version
	hp	V	rpm	A	hp	V	rpm	A	

01	0.7	175-260/300-450	1420	3.8/2.2	0.9	202-300/350-520	1700	3.9/2.25	IP54 • ISO F
----	-----	-----------------	------	---------	-----	-----------------	------	----------	--------------

1~ Motor									
#	50 Hz				60 Hz				Version
	hp	V	rpm	A	hp	V	rpm	A	

02	0.7	230 \pm 10%	1360	4.6	0.9	230 \pm 10%	1600	5.2	IP54 • ISO F 20 μ F (450 V)
----	-----	---------------	------	-----	-----	---------------	------	-----	------------------------------------

03					0.9	115 \pm 6%	1630	9.5	UL(E123782) IP54 • ISO F 80 μ F (240 V)
----	--	--	--	--	-----	--------------	------	-----	---------------------------------------------------

- Current consumption and rotation speed may vary. Tolerance in each case -1.5/+2%

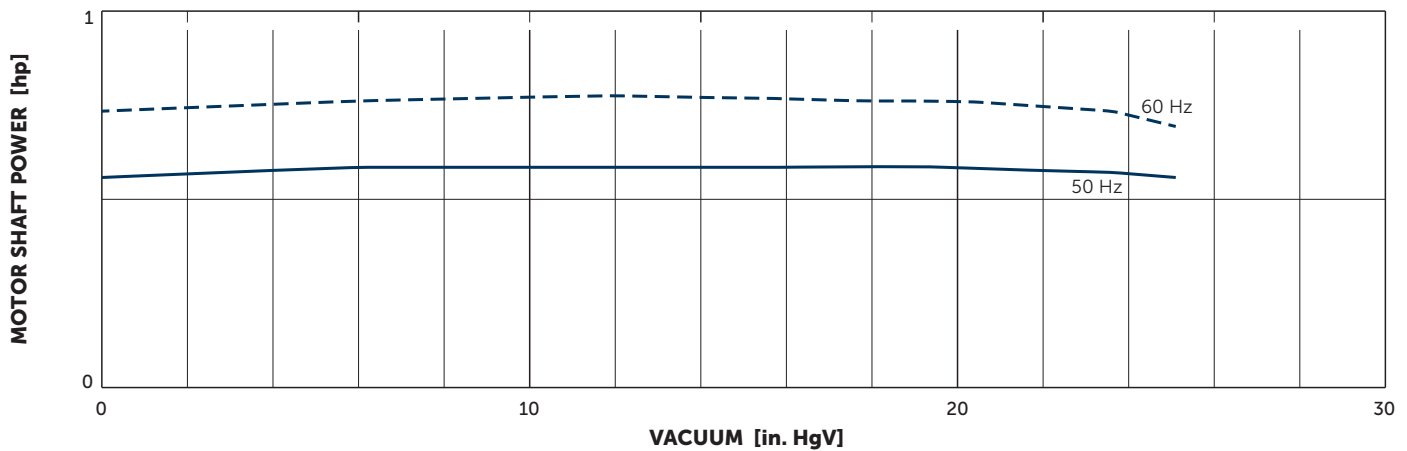
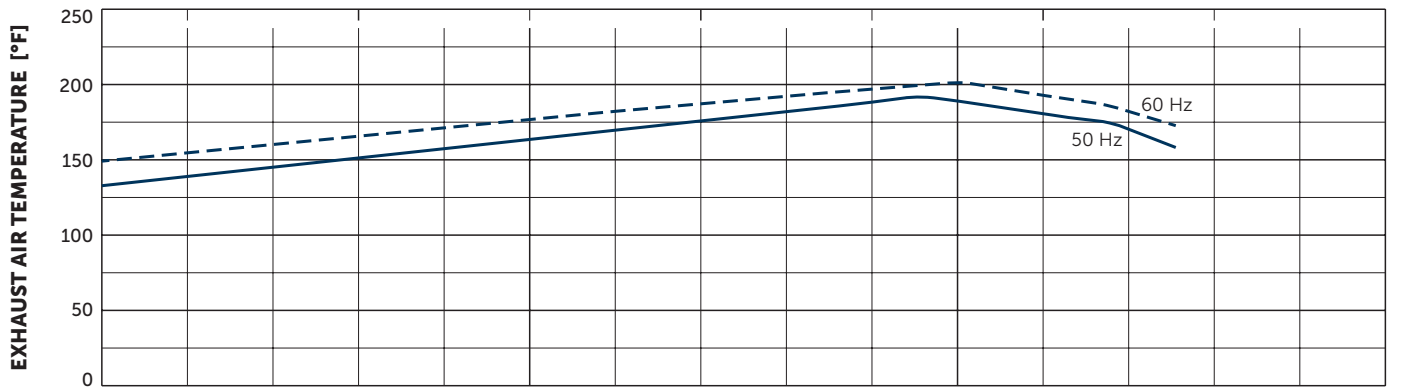
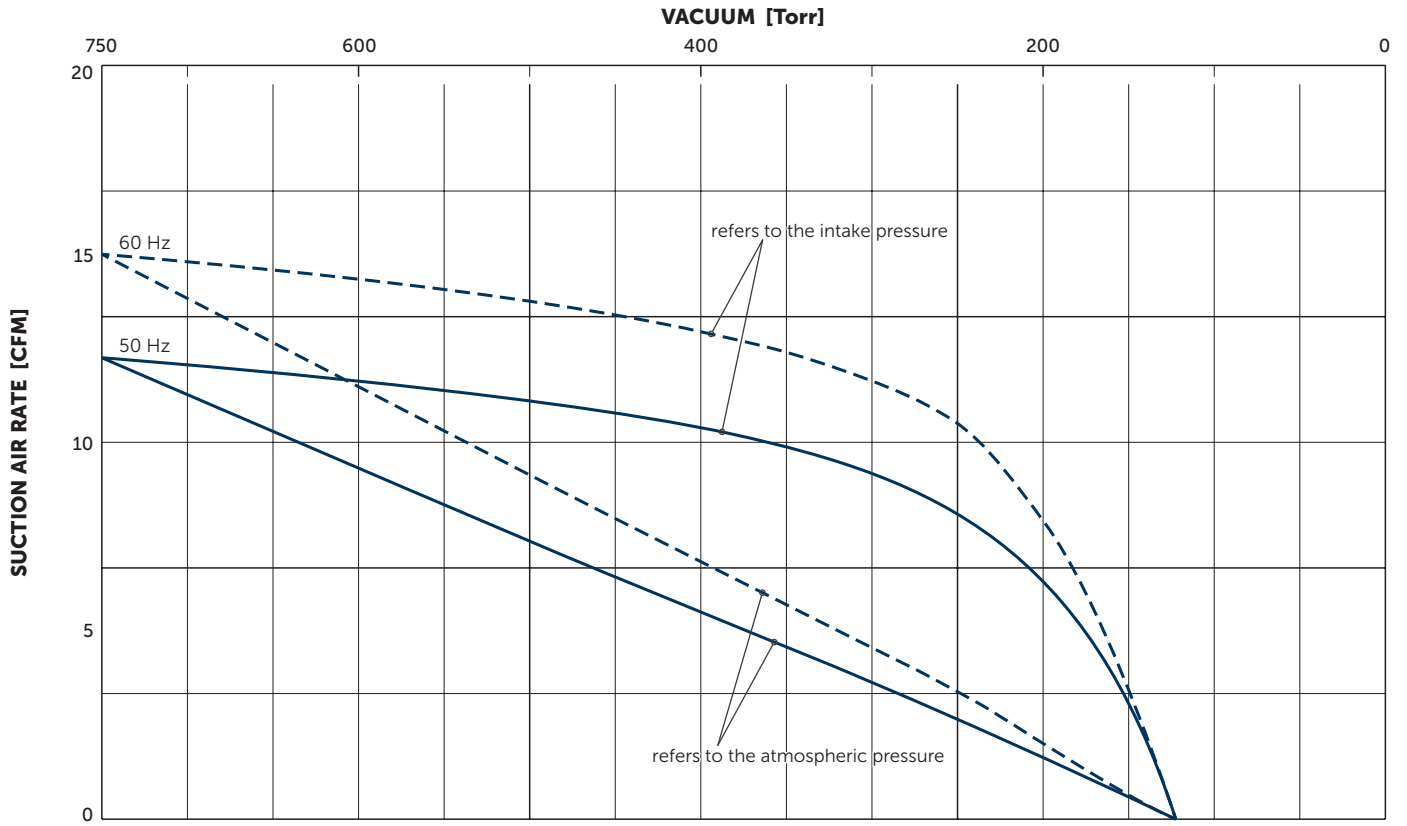

Reference data (atmosphere): 0 in. HgV, 68°F; Tolerance: ±5%

+ VARIANTS AND ACCESSORIES

VX 4.16

SERIES X: BECKER INNOVATION WITH TOP WARRANTY

Equipped with specially developed vanes, these oil-free rotary vane pumps distinguish themselves by high abrasion resistance, and with that extremely long service lives. Due to the low wear there is also minimal dust, so the series X pumps are perfectly suited for precision processes under clean room conditions.

This innovation branded by Becker is outstanding not only because of its 100 percent oil-free operation, excellent degree of efficiency and low power consumption.

In the area of sensitive vacuum, series X also guarantees precise low-pulsation air conduction.

Becker guarantees for these pumps a vane life-time of 20,000 operating hours or a maximum of 3 years. The enhanced longevity of X series pumps also extends service life intervals, and can cut out the need for frequent service visits with costly pump failures now no longer an issue.



ADVANTAGES

- Quick, clean and quiet
- Oil-free
- Wear resistant
- Energy saving
- Long-life reliability
- Ultimate pressure 26.6 in. HgV

OTHER VARIANTS AND ACCESSORIES

- With external suction filter, e.g. series FV¹⁾
- Sound proof box SH 20¹⁾



Example for an external suction filter



Sound proof box SH 20

¹⁾ See separate data sheet

- Possible combinations on request



MAKE IT BECKER.

