



VERSAMAC⁺

The Versatility of Binding

Semi Automatic Desktop Punching And Ejector Machine

OPERATION MANUAL

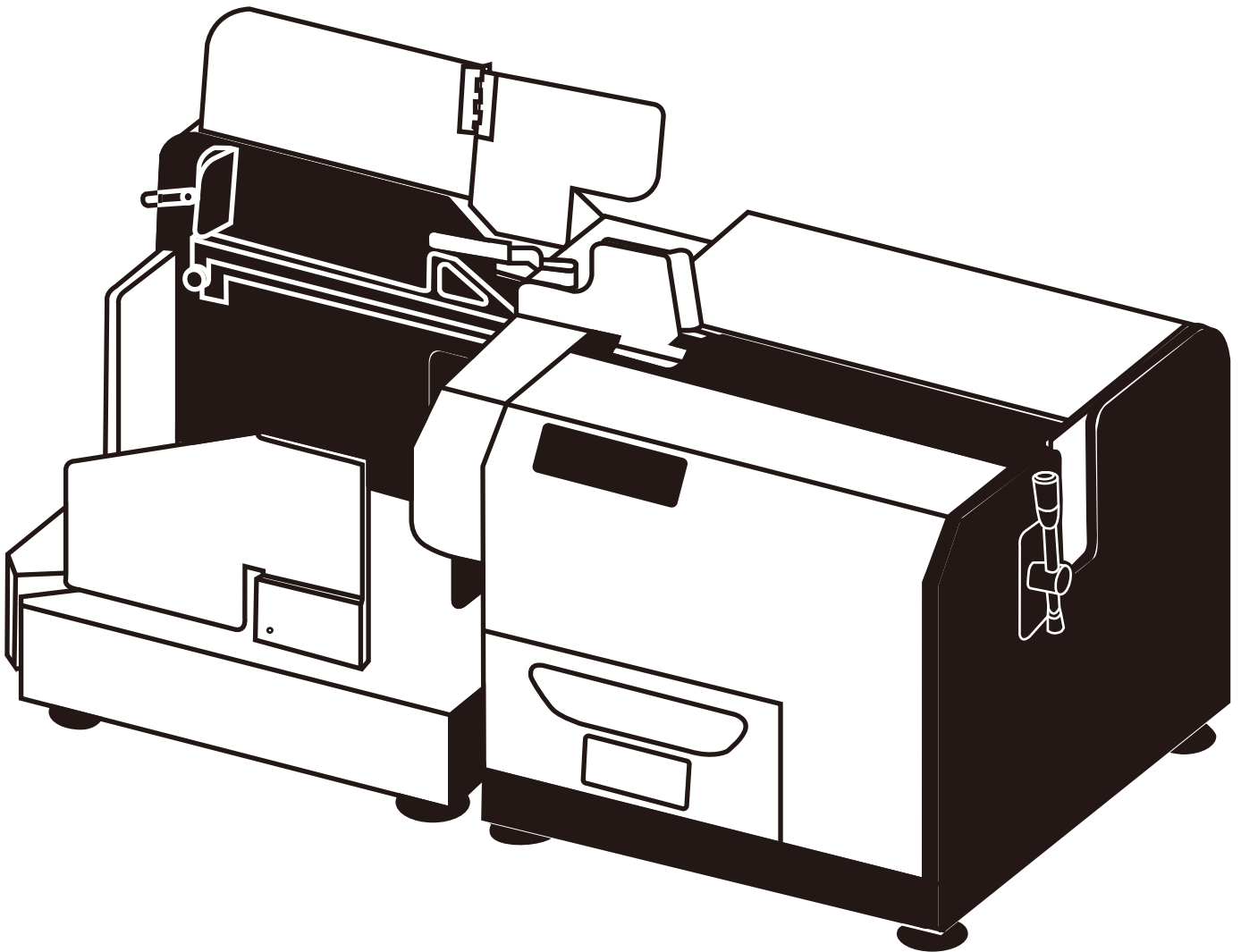

TABLE OF CONTENTS

Introduction	Page 1
Features	Page 1
Maintenance Accessories	Page 2
Assembly & Safety Instructions	Page 3
Punch Patterns	Page 4
Installation of Punch Die	Page 5
Disengagement (Removal) of Punch Pins	Page 6
Punching	Page 7
Collecting Unit Setup	Page 8
Changing of Punch Die	Page 9
Punch Die Maintenance	Page 10
Troubleshooting	Page 11
Warranty Policy	Page 13

INTRODUCTION

Congratulations on the purchase of your new **VERSAMAC⁺**, a professional and heavy-duty punching machine. Your **VERSAMAC⁺** was designed with a full range of functions & safety features, along with premium quality components to guarantee an effortless and pleasant book binding experience, as well as many years of trouble-free service.

IMPORTANT

We recommend that you take a moment to familiarize yourself with the functions of your new **VERSAMAC⁺**. Make sure you read all the features and safety instructions, and follow these guidelines to install, operate and maintain your **VERSAMAC⁺**. You will find that with just a little practice, any person can achieve professional results.

FEATURES

Punch Unit

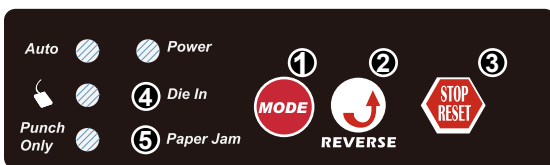

Manual Control Panel

- ① Mode Switch Button
- ② Reverse (Anti-Jam) Switch
- ③ Emergency Stop Switch
- ④ Power & Die-in Indicator
- ⑤ Paper Jam Indicator

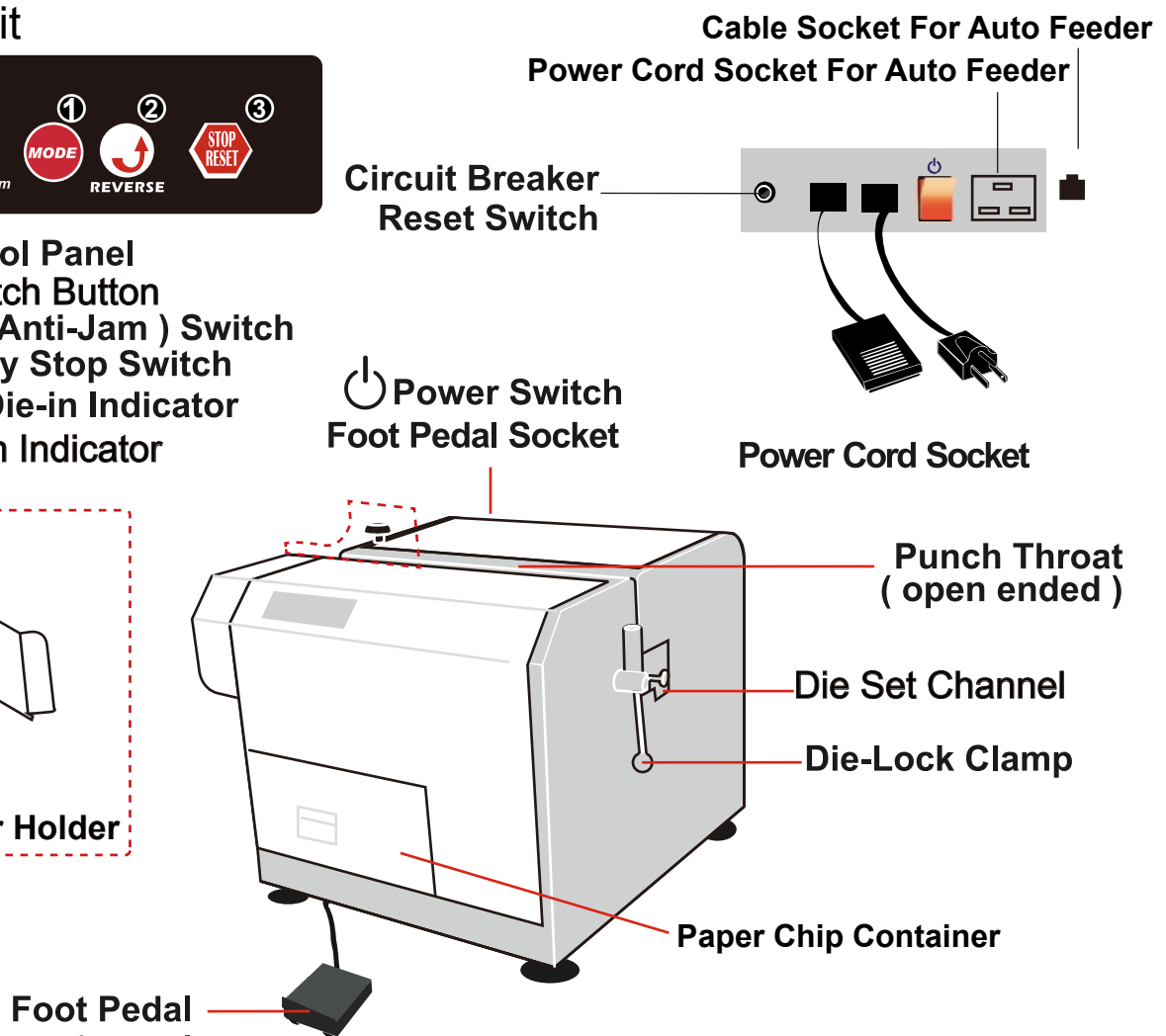
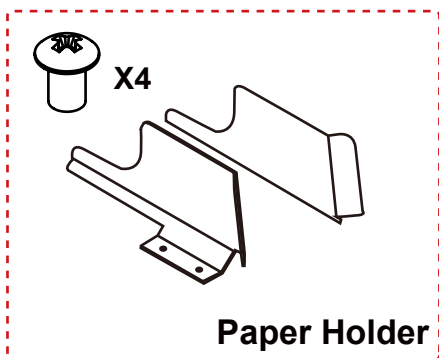

Stacker Unit

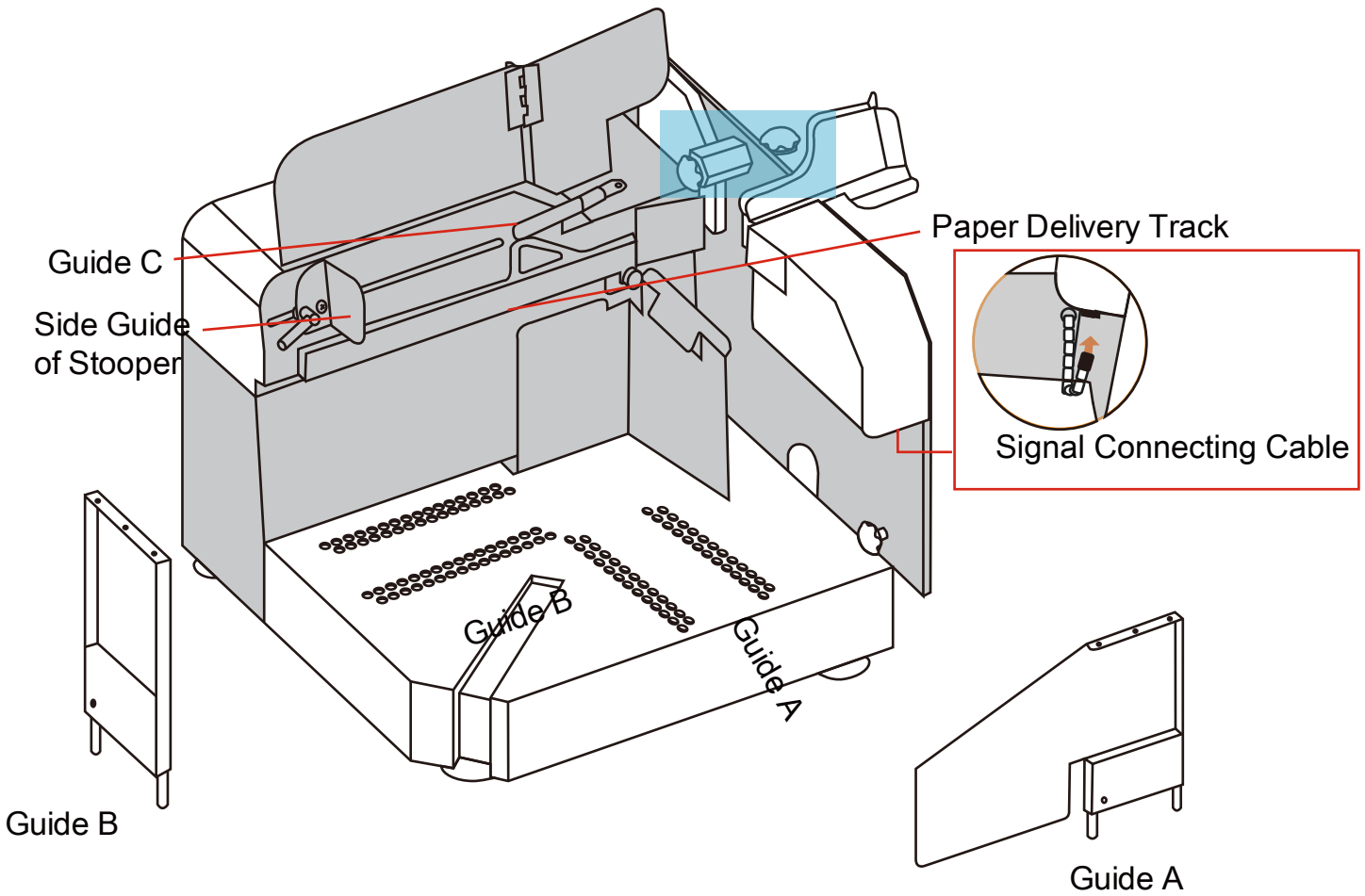
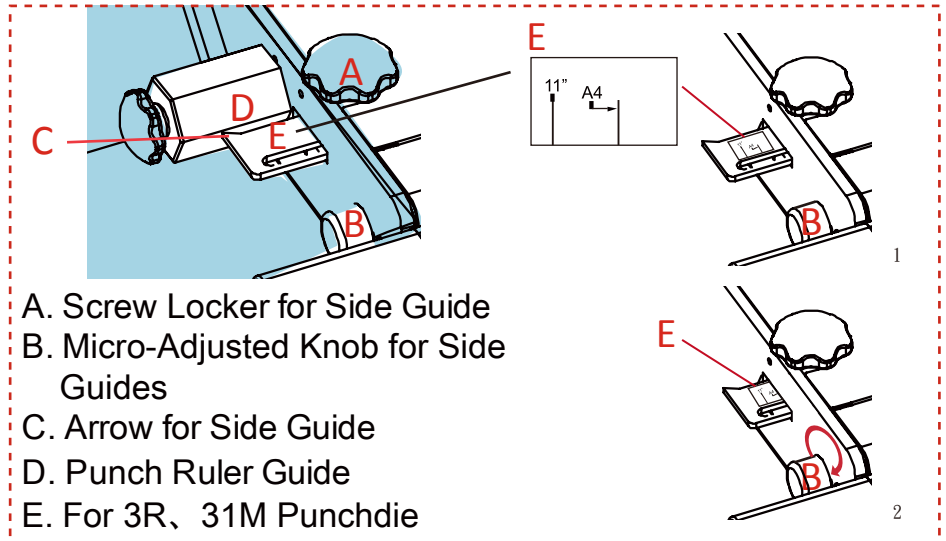

MAINTENANCE ACCESSORIES

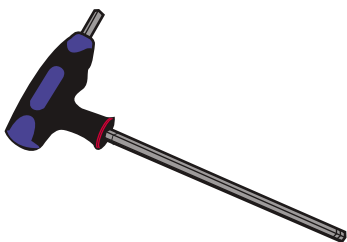

Allen Key Wrench #8

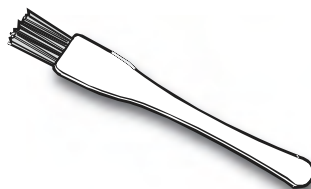

Cleaning Brush



Anti-Rust Lubricant

ASSEMBLY & SAFETY INSTRUCTIONS

1. Place your new **VERSAMAC⁺** on top of a sturdy work table. **The machine weighs over 220 lbs and cannot be lifted by One Person!** It should be lifted by at least 2 persons. **See Picture 1**
2. Connect the Punch Unit and Collecting Unit by locking 3 screws and attaching the connection cable. **See Picture 2**
3. Plug the POWER CORD and FOOT PEDAL CORD into the back of the machine. **See Picture 3**
4. If necessary, adjust the height of legs of your **VERSAMAC⁺** so that it stands firmly and evenly. **See Picture 4**
5. Place the Foot Pedal on the floor in front of the machine. **See Picture 5**

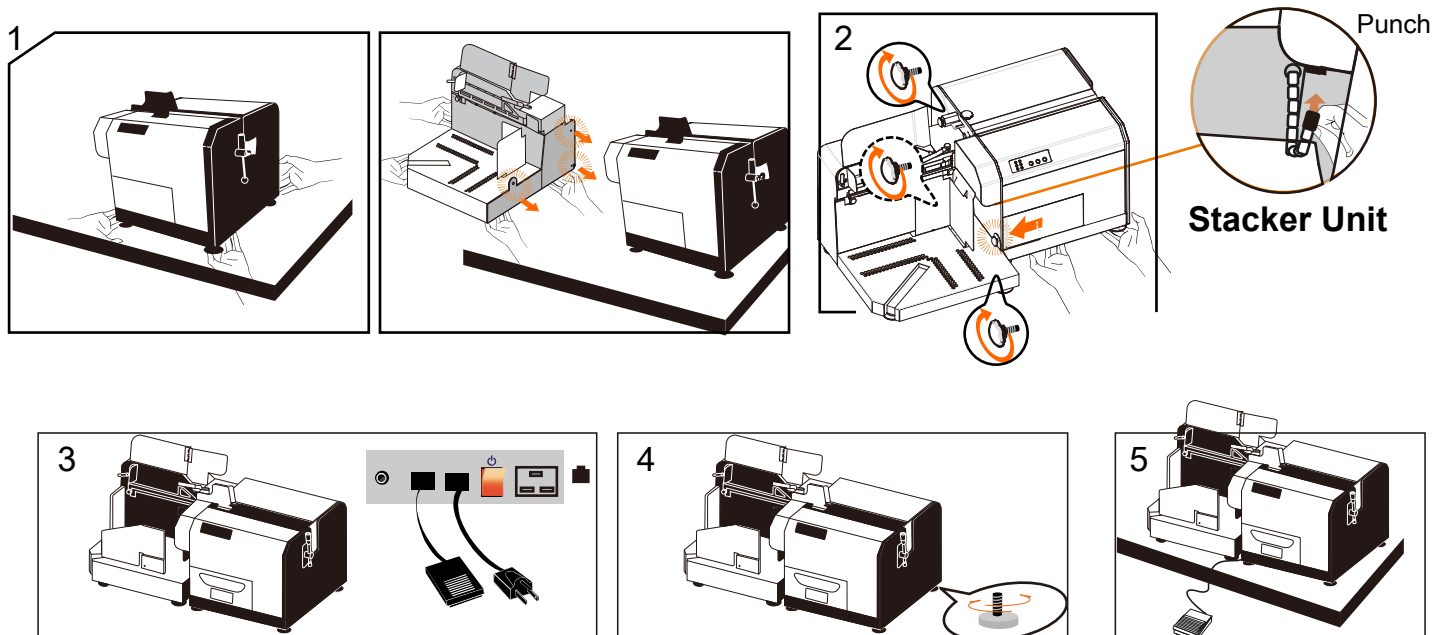

6. Plug the other end of POWER CORD into an outlet with the correct voltage and type. Powering the machine with incorrect voltage may severely damage its electrical components and result in personal injury!
7. **IMPORTANT:** Always turn Main Power Switch OFF and place Foot Pedal out of reach before setting up, performing maintenance, or changing dies on the **VERSAMAC⁺**.
8. To reduce the risk of electrical shock, never operate the **VERSAMAC⁺** near water.
9. Do not use **VERSAMAC⁺** if the Power Cord or Foot Pedal Cord is damaged.
10. Do not allow the electric cords to be in contact with hot surfaces.
11. Never fix the **VERSAMAC⁺** by hand without powering off the unit and unplugging the power cord.
12. Turn off the power of **VERSAMAC⁺** before changing dies or maintaining the machine.
13. Punched sheets are delivered from the stacker unit to the collecting unit. Be reminded to keep fingers, hair, jewelry, neckties, and other loose clothing or objects away from the delivery trail.

PUNCH PATTERNS

Standard Punch Patterns :

COIL 4:1 (OVAL)

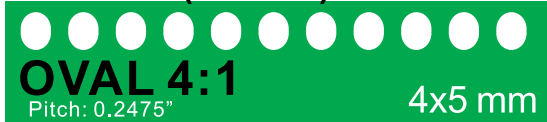

Adjustable margin: 2mm, 3mm, 4mm or 5mm

COIL 4:1 (ROUND)



Adjustable margin: 2mm, 3mm, 4mm or 5mm

WIRE 3:1 (SQUARE)



Adjustable margin: 2mm, 3mm, 4mm or 5mm

WIRE 2:1 (RECTANGULAR)

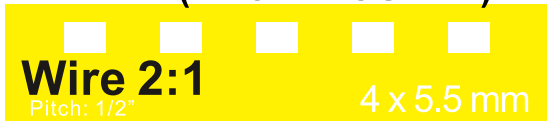

Adjustable margin: 2mm, 3mm, 4mm or 5mm

COMB (RECTANGULAR)



Adjustable margin: 2mm, 3mm, 4mm or 5mm

3 HOLE (ROUND)



Fixed margin at 1/4"

Other Available Punch Patterns :

COIL 6MM (ROUND)



Adjustable margin: 2mm, 3mm, 4mm or 5mm

COIL 6MM (OVAL)



Adjustable margin: 2mm, 3mm, 4mm or 5mm

COIL 5MM (ROUND)



Adjustable margin: 2mm, 3mm, 4mm or 5mm

WIRE 3:1 (ROUND)



Adjustable margin: 2mm, 3mm, 4mm or 5mm

WIRE 2:1 (ROUND)



Adjustable margin: 2mm, 3mm, 4mm or 5mm

VELO (ROUND)



Fixed margin at 1/16"

REMARK:

1. Pitch: Distance from center of a hole to center of another hole.
2. Margin: Distance from edge of paper to the nearest edge of the hole.
3. More punch patterns may be available. Contact your dealer for our most up to date list of punch patterns.

INSTALLATION OF PUNCH DIE

Main Power must be switched OFF before punch die installation begins.

1. From the right-hand side of the machine, insert the punch die into the Die Set Channel. **See Picture 1**
2. Slide the punch die all the way in. **See Picture 2**
3. Turn the Die Locking Clamp **clockwise** to securely lock the punch die in place. **See Picture 2 & 3**
4. Turn the Main Power Switch ON. The indicator light for “Die In” will turn green.
5. Make the appropriate adjustment to select the Depth Margin position best suited for your job. There are 4 available depth margin positions in each punch die (2mm, 3mm, 4mm and 5mm from edge of paper to the nearest edge of hole). Adjustments can be done by **PULLING** or **PUSHING** the Depth Margin Control Bar towards the **LEFT** or **RIGHT** side of the machine. **See Picture 4**

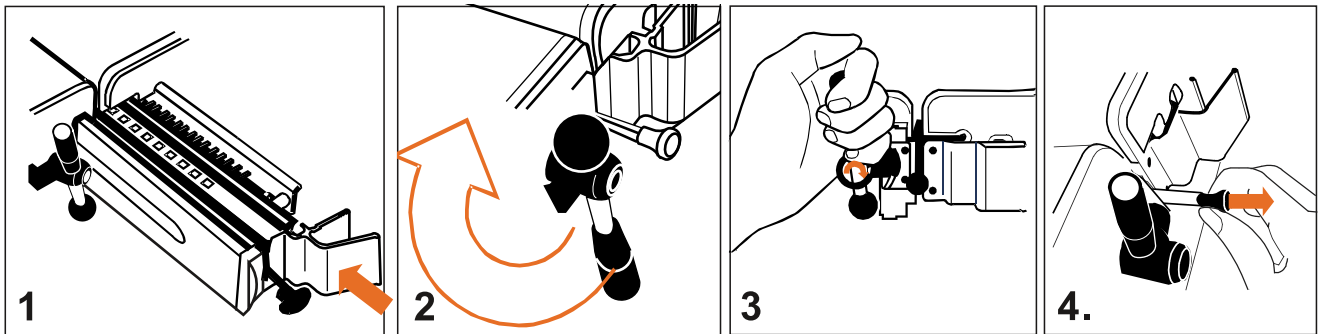

TIPS

The exact position of Depth Margin is based on the book thickness and operator's preference. However, as a rule of thumb, an ideal Depth Margin setting should allow easy turning of the pages while providing enough tear resistance to the sheet.

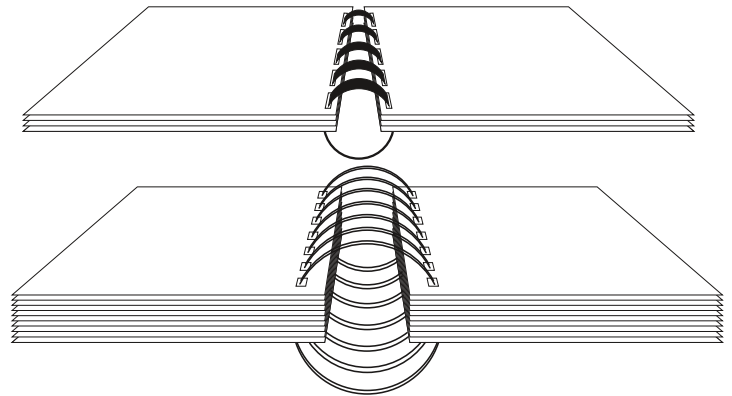

Remark:

1. No Depth Margin adjustment is available on Velo & 3 Hole punch patterns.
2. Never pull or push the Depth Margin Control Bar **UPWARD** or **DOWNWARD**. Doing so may damage the Depth Margin Control mechanism in your punch die.

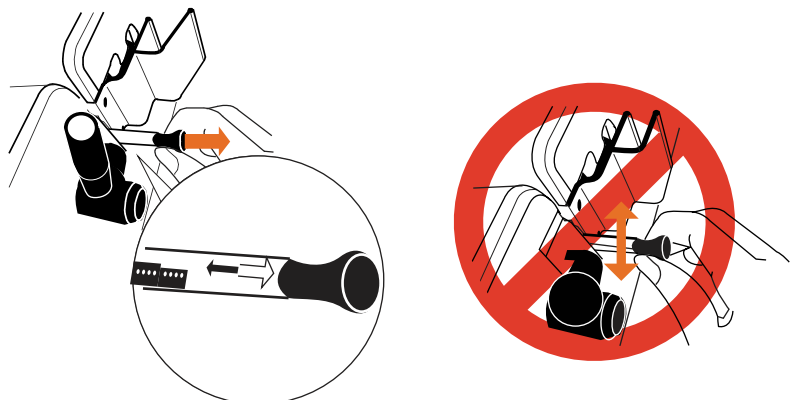

DISENGAGEMENT (REMOVAL) OF PUNCH PINS

To avoid partially punched holes, follow the simple steps below to disengage (remove) the corresponding punch pin in the die set.

For most standard sheet sizes, you can easily find the holes that need to be disengaged (removed) from the Punch Ruler Guide label on each die. Just look for the sheet size that you are using, and identify the appropriate punch pin that will create a partial punched hole in your sheet. **See examples below**

Partially punched hole on a 11" sheet

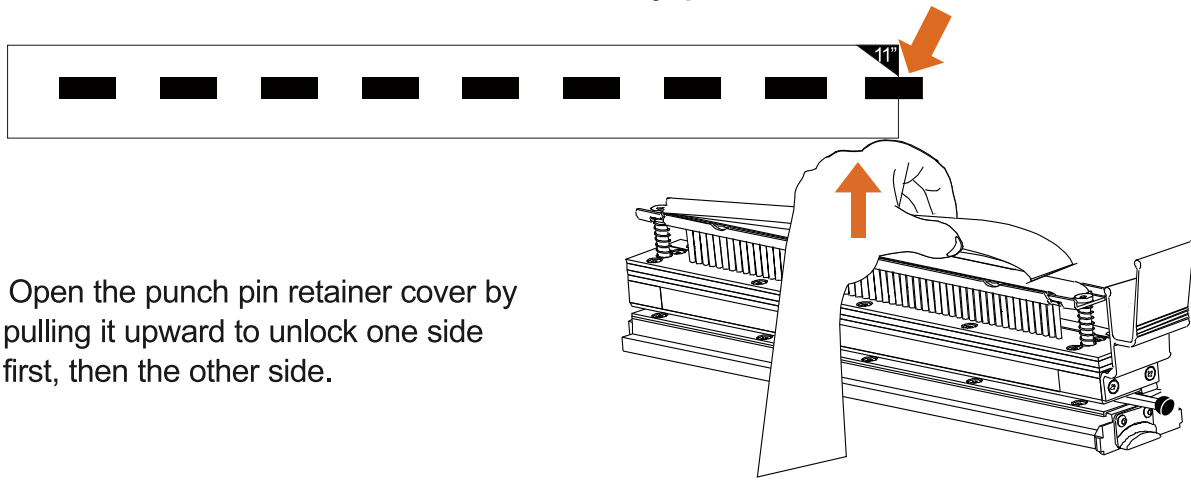

1. Open the punch pin retainer cover by pulling it upward to unlock one side first, then the other side.

2. Remove the desired punch pin from the die set.

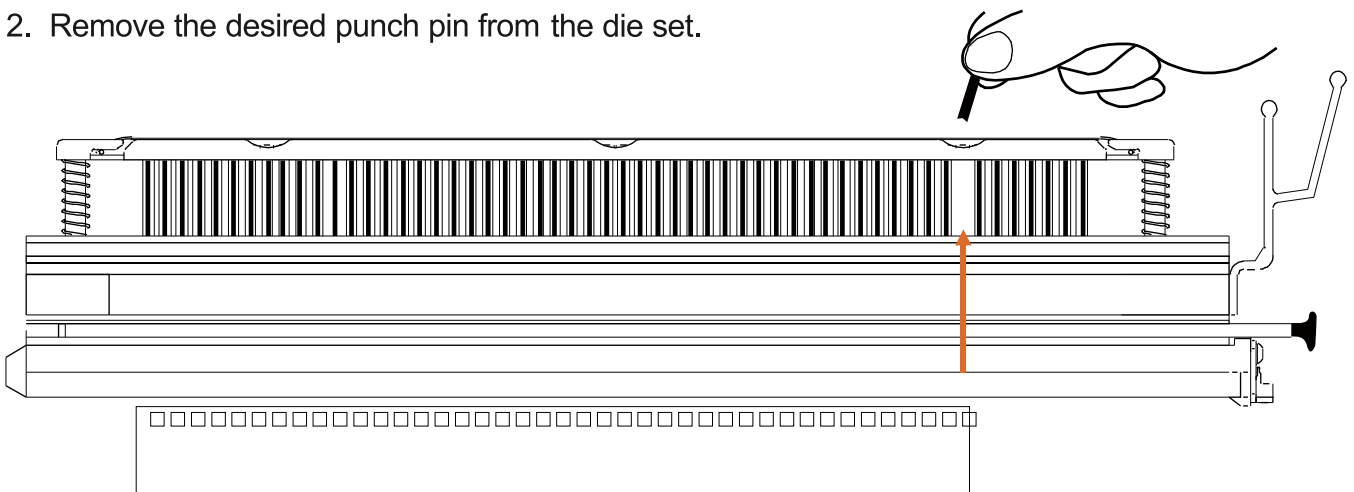

3. Re-Install the punch pin retainer cover onto the die set. Make sure both sides of the retainer cover are securely locked in place.

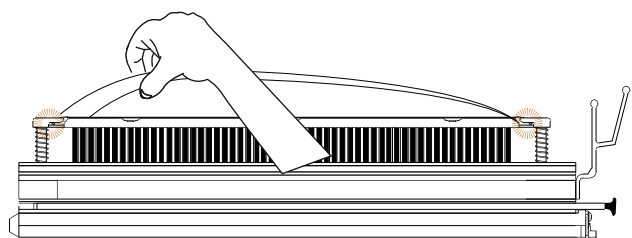

PUNCHING

IMPORTANT:

Before operating the machine, always make sure that the **Punching Die** is **FULLY INSERTED** and the lamp is in **LOCKED** position. **See Picture 1**

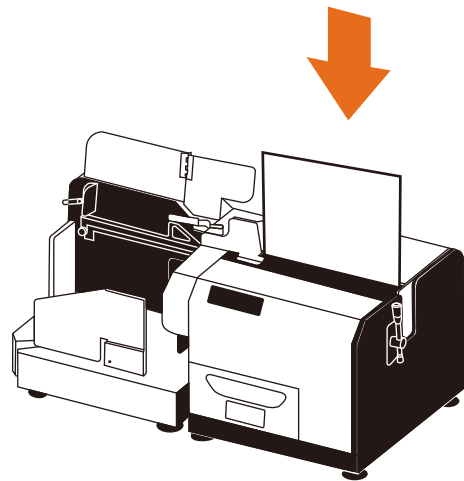

1. Turn on the power switch. Both LED indicator lights at manual control panel should light up. **See Picture 2**

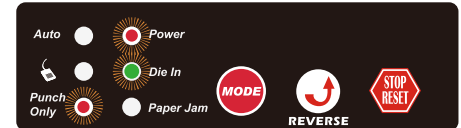
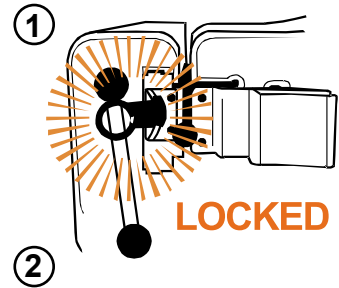

2. Align the **Side Margin Control** to the correct position according to the punch die installed and sheet (or cover) size being used. **See Picture 3**

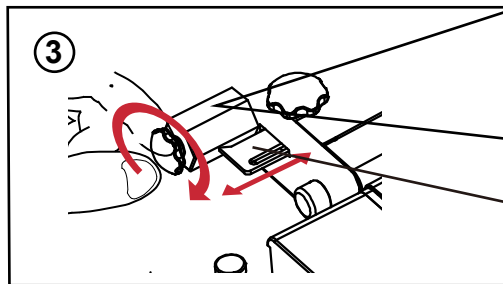
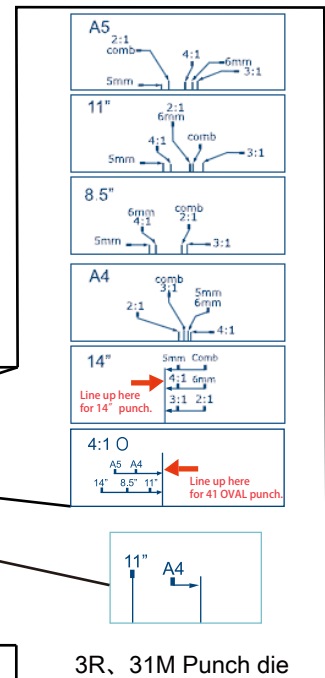

3R、31M Punch die

3. Press "mode" button at manual control panel to select the preferred mode. **See Picture 4**

Punching Modes

Auto Mode : Insert sheets into the punch throat from right-hand side of the machine, then slide it towards the left to activate the automatic punching and paper ejection.

Foot Pedal Mode:

Activate the punching and paper ejection by stepping on the foot pedal.

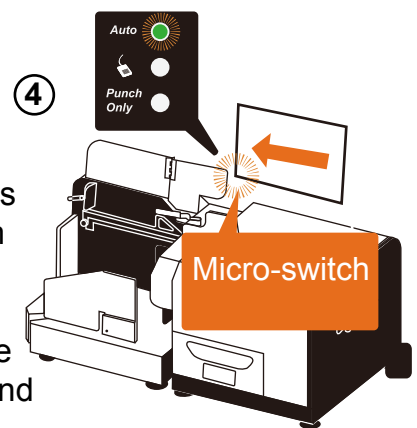

Punch Only Mode:

Activate the punching action by stepping on the Foot Pedal. Paper will not be ejected.

TIPS

Maximum single punch capacity of 25 sheets (20 lb paper). **The number of sheets depends on the**

For maximum equipment durability, we recommend 1.5mm Thickness per punch.

When punching acetate or other types of heavier stock, always punch fewer sheets.

Check and empty the Paper Chip Container frequently.

If the paper chip container overflows, the punch die or the machine may be damaged.

Stacker Unit Setup

1. position guide a.b by different sheet size . **See Picture 1**

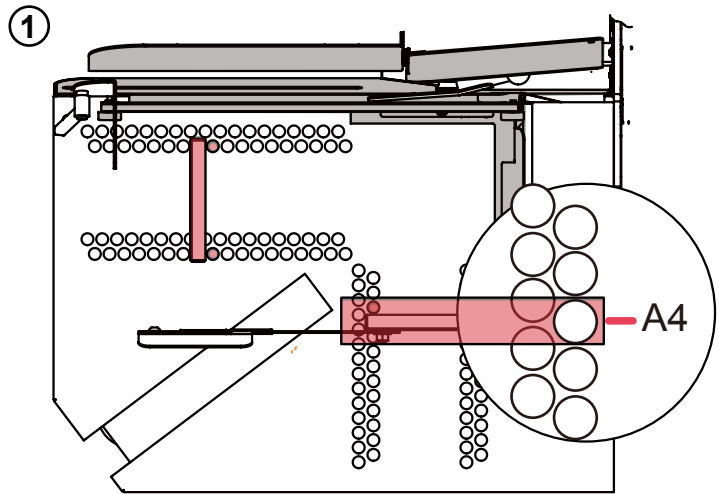
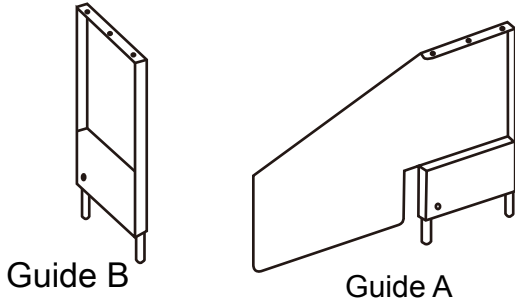

2. Lift paper delivery guide. **See Picture 2**

3. Adjust paper stopper to match the size of the punched paper. **See Picture 3**

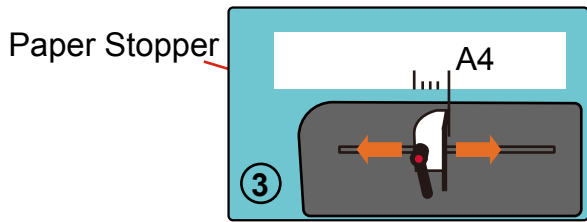

4. Pull out the guide C when punching A4 size sheets. **See Picture 4**

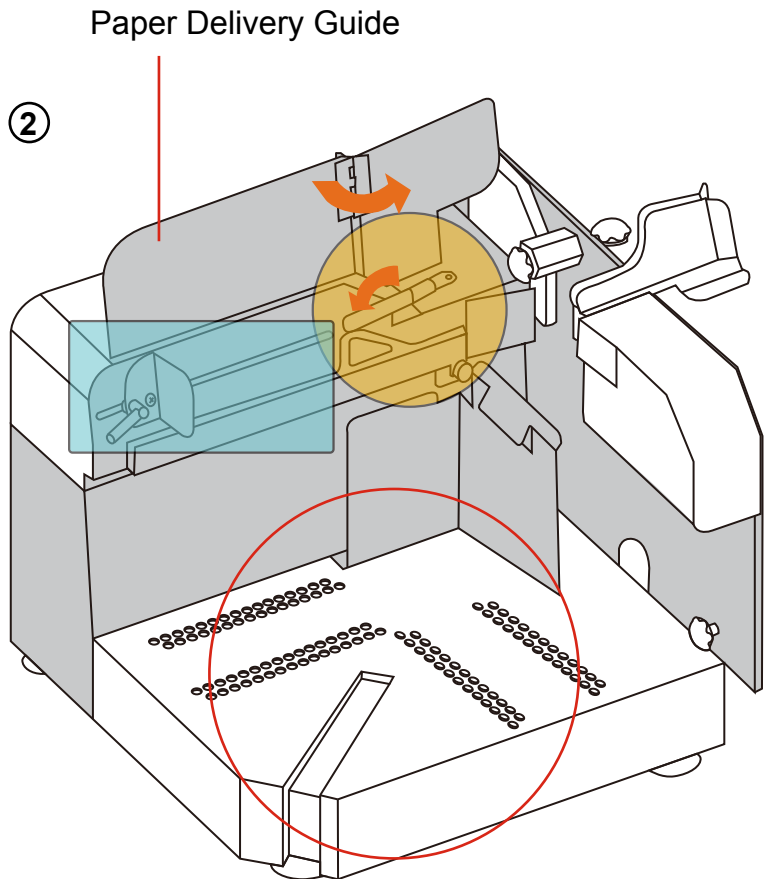
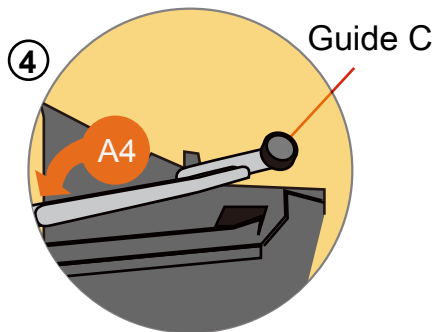

CHANGING PUNCH DIE

IMPORTANT:

Always switch off power when changing the Punch Die. **See Picture 1**

Do NOT turn on power before the Punch Die is fully inserted and the clamp is in the LOCKED position. **See Picture 2**

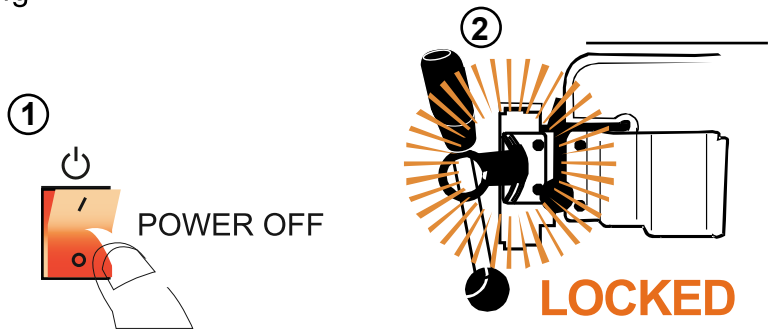

By following the simple steps below, you can quickly and easily change the punch die of your **VERSAMAC⁺** within seconds:

1. Lift up the lever of the Die-lock Clamp and turn it counterclockwise to unlock the Punch Die. **See Picture 3** During the turn, also make sure that the lever does not hit the Depth Margin Adjustment bar. **See Picture 4**
2. Gently pull on the Punch Die Handle to slide the existing Punch Die out of your **VERSAMAC⁺**. **See Picture 5** When the Punch Die is about half way out, use **both hands** to hold the die and remove it completely. (Each Punch Die weighs over 10 Lbs and is too heavy to be handled by just one hand) **See Picture 6**

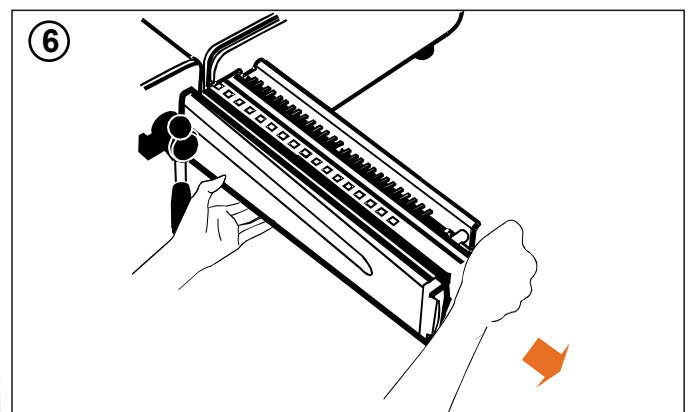
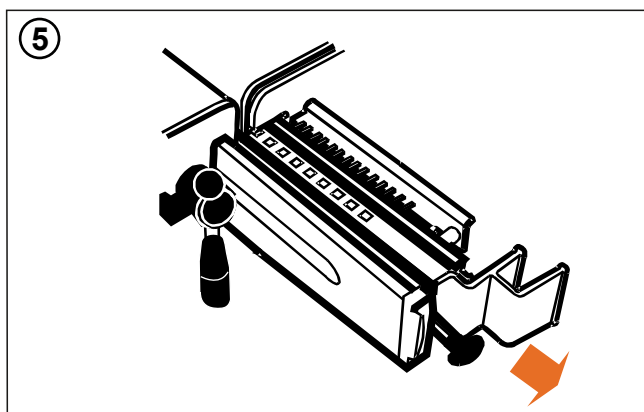
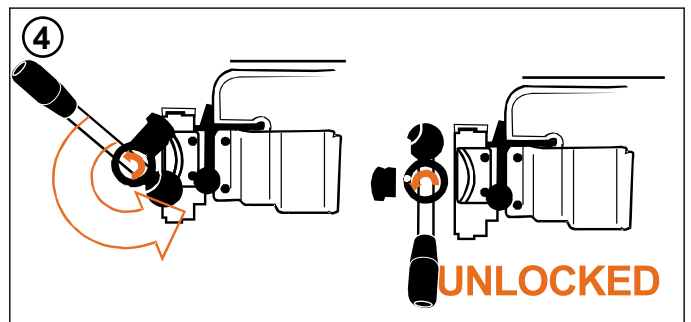
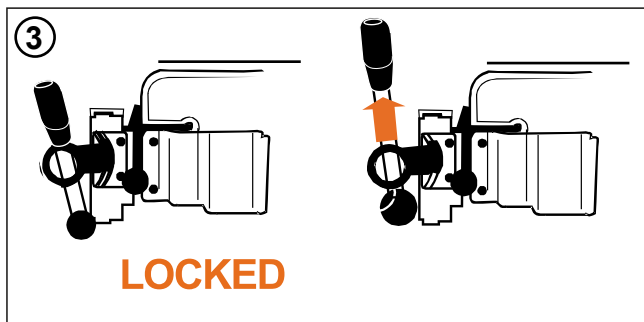

3. Use the included Cleaning Brush to remove any paper debris out of Punch Throat and other opening areas in your **VERSAMAC⁺**.
4. Install a different Punch Die into the machine by following the instructions on Page 5 of this Operational Manual.

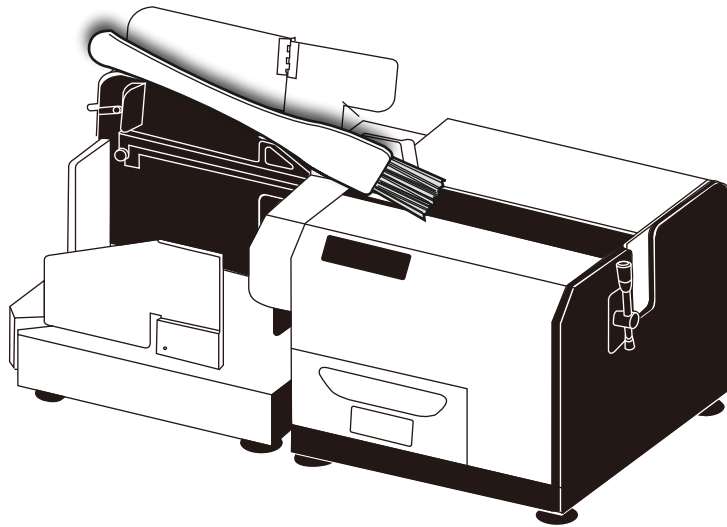

PUNCH DIE MAINTENANCE

To keep your **VERSAMAC⁺** running in the optimal condition at all times, Punch Die Maintenance should be performed on a regular basis. To do so, simply remove the punch die from machine following instructions on Page 9. Then carefully apply the anti-rust lubricant (included accessory item) onto all the punch pins in the die set. Re-install the punch die into the machine and remove excessive lubricant by punching some scratch paper.

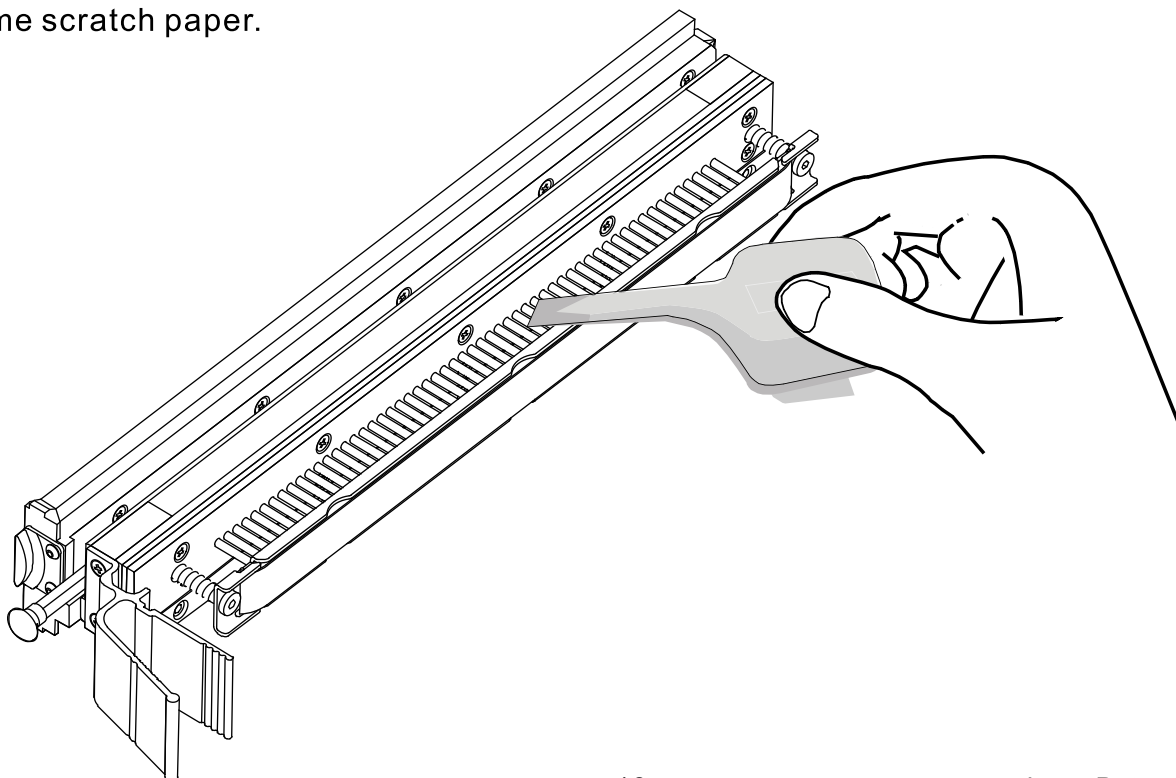

Electric Jam Release:

Thanks to the advanced design of the **VERSAMAC⁺** electronic circuit board, the punching action will automatically stop in case of sheet overload. When this occurs, simply press the **Reverse (Anti-Jam) Switch** on the Manual Control Panel repeatedly, until the motor & punch pins are returned to the original home position. Then take out some sheets and resume your punching action again.

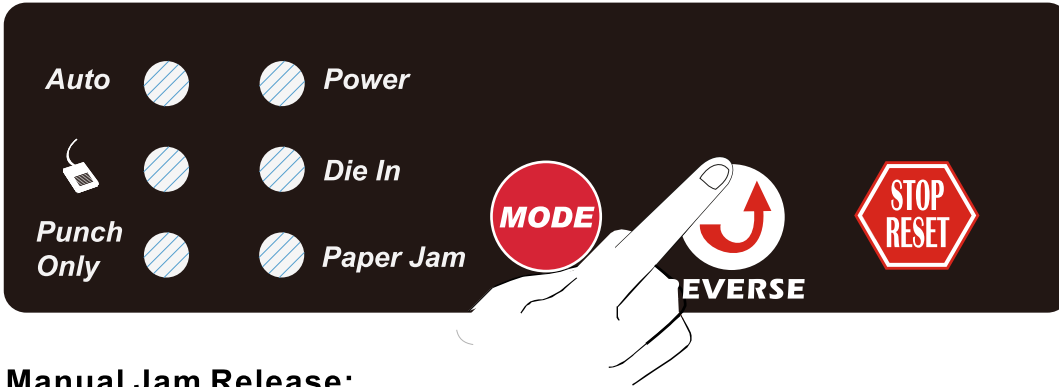

Manual Jam Release:

If for any reason the punching pins are not able to return to their original home position by pressing the Reverse (Anti-Jam) Switch, a **Manual Reverse Procedure** may be necessary to clear up the jam:

1. First, remove the power cord from the machine.
2. Insert the **#8 Allen Key Wrench** (included accessory of VersaMac) into the hole in the left side panel of the machine.
3. If the punch action stopped **before** all the punch pins reached their, fully extended position, turn the **#8 Allen Key Wrench counterclockwise** to pull the punch pins out of the sheet.
4. If the punch action stopped **after** all the punch pins reached their, fully extended position, turn the **#8 Allen Key Wrench clockwise** to continue the punch pins out of the sheet.
5. Remove all sheets from the punch throat.
6. Remove **#8 Allen Key Wrench** from the machine, then turn **ON** the power and press the foot pedal to make sure the machine operates correctly. You might also need to reset the circuit breaker by pressing the **Circuit Breaker Reset Switch** at the rear of the machine.

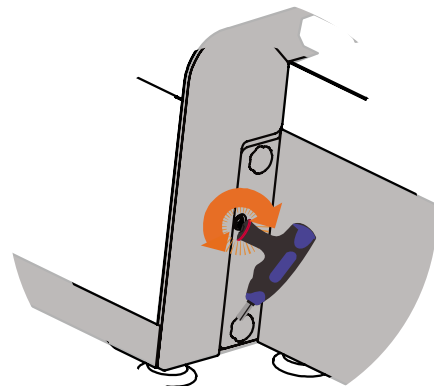
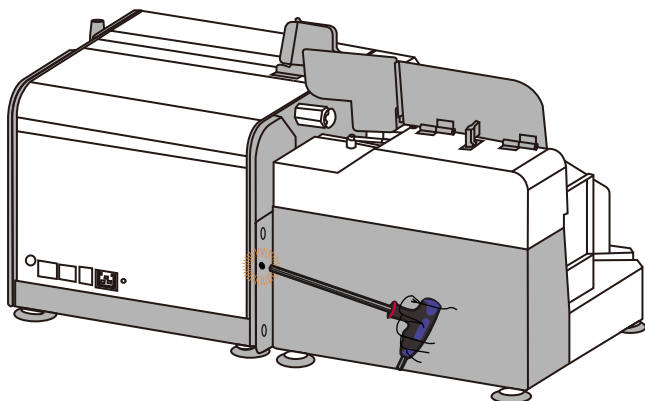

TROUBLESHOOTING

Machine is switched on, but it won't work at all.

PROBLEM	ACTION
The Power Indicator Light on the Control Panel is ON.	Plug in the power cord properly, and make sure Power Switch is turned ON.
Circuit breaker tripped due to the different electrical voltage used than the one specified on VersaMac label.	Plug the power cord into an outlet with the correct voltage, and press Circuit Breaker Reset Switch to reset it.
The Die-In Indicator Light on the Control Panel is ON.	Make sure the punch die is FULLY INSERTED and the clamp is in LOCKED position.
Top Cover is open and the safety sensor has been activated.	Make sure that the Top Cover is closed to deactivate the safety sensor.
#8 Allen Key Wrench is inserted into the machine and safety sensor has been activated.	Remove the #8 Allen Key Wrench from the machine to deactivate the safety sensor.
Foot pedal has been pressed but machine does not work.	Make sure Foot Pedal cord is properly plugged into the machine and the correct mode is selected.

Paper Jam

PROBLEM	ACTION
Punch action stopped before the cycle ended.	Follow instructions on Page 11 to clear up the paper jam. Punch again with reduced number of sheets.
Punch Die not properly installed in VERSAMAC⁺ .	Make sure both sides of the Pin Retainer Cover are securely locked in place, and that the punch die is fully inserted into the machine with the clamp locked.
Punching action becomes more noisy than normal and punch pins lack lubrication	Follow instructions on Page 9 to perform Punch Die Maintenance and lubricate all the punch pins.
Paper Chip Container is overflowed.	Empty the Paper Chip Container.

