







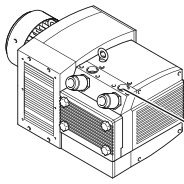

**BETRIEBSANLEITUNG
OPERATING INSTRUCTIONS
INSTRUCTIONS DE SERVICE
ISTRUZIONI D'USO
HANDLEIDING
INSTRUCCIONES PARA EL MANEJO
MANUAL DE INSTRUÇÕES
NAUDOJIMOSI INSTRUKCIJA
KASUTUSJUHEND
LIETOŠANAS INSTRUKCIJA
DRIFTSINSTRUKS
DRIFTSINSTRUKTIONER
DRIFTSVEJLEDNING
INSTRUKCJA OBSŁUGI**

**KEZELÉSI ÚTMUTATÓ
NÁVOD K OBSLUZE
NAVODILO ZA UPORABO
NÁVOD NA OBSLUHU
UPUTE ZA RAD
MANUAL DE OPERATII
TREORACHA OIBRIÚCHÁIN
ΟΔΗΓΙΕΣ ΧΡΗΣΗΣ
EL KITABI
ИНСТРУКЦИИ ЗА ЕКСПЛУАТАЦИЯ
ИНСТРУКЦИЯ ПО ЕКСПЛУАТАЦИИ
取扱説明書
사용설명서
使用说明书**



DVT 3.80

MAKE IT BECKER.



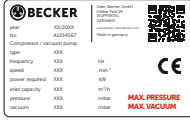

 		
		
 <p>AIR</p>		
		

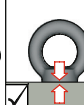

1

<p>MAX. PRESSURE</p> <p>MAX. VACUUM</p>		<p>mbar</p>
	 <p>MAX.</p>	
<p>L_{pA})))</p> <p>DIN EN ISO 11203 Accuracy Class 2 K_{pA} = 3 dB(A) l ← 1m</p>		<p>L_{pA} = 76 dB(A) - 50Hz</p> <p>L_{pA} = 77 dB(A) - 60Hz</p>

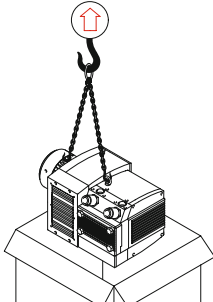



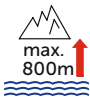
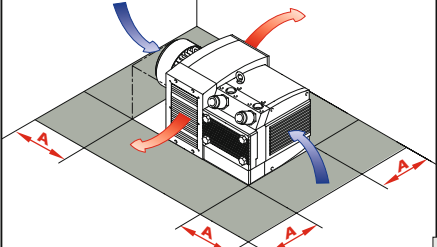

2

			 <p>72 kg 159 lbs</p>
			

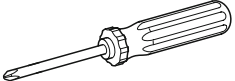
3

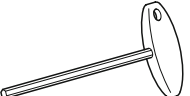
<p>A > 100mm A > 4"</p>	 <p>> 5°C/41°F < 45°C/113°F</p>	 <p>max. 90%</p>	 <p>max. 800m</p>
			

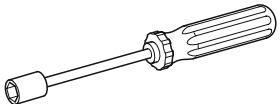
4

 <p>No. 2</p>	
 <p>5 mm</p>	
 <p>7 mm</p>	
 <p>10 mm</p>	

5

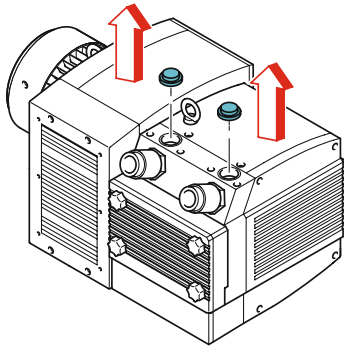

6

MOTOR-PROTECTION
=

(CF 1,XX)	
50Hz	60Hz
XXX / XXX V	XXX / XXX V
(XX / XX A)	(XX / XX A)

SERVICE FACTOR
X
RATED CURRENT

7

optional

Bi-metal

PTC

1) motor protection switch

8

9

10

PRESSURE

0 2 10 [m]

VACUUM

11

BECKER

year: XXX/20XX
 no: A1234567
 Compressor / vacuum pump
 type: XXXX
 frequency: XXXX Hz
 speed: XXXX rpm
 power required: XXXX kW
 inlet capacity: XXXX m³/h
 pressure: XXXX mbar
 vacuum: XXXX mbar

PRESSURE

VACUUM

12

Maintenance



13

14

<p>CLEANING INTERVAL</p>	<p>SUCTION AIR</p>	<p>40h</p> <p>↑ ↓</p> <p>200h</p> <p>EN149 - FFP3 42 CFR 84 - N100</p>
---------------------------------	--------------------	--

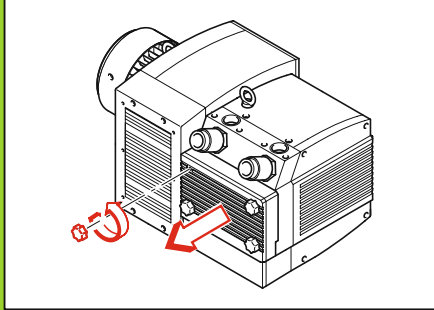

15

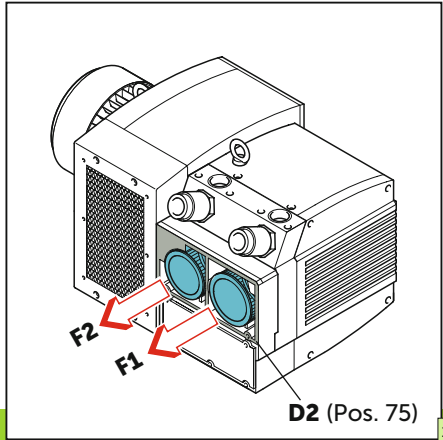

16

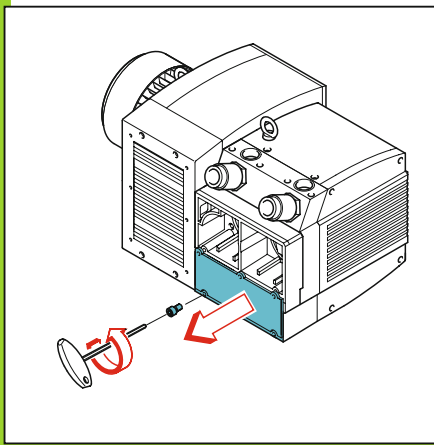

17

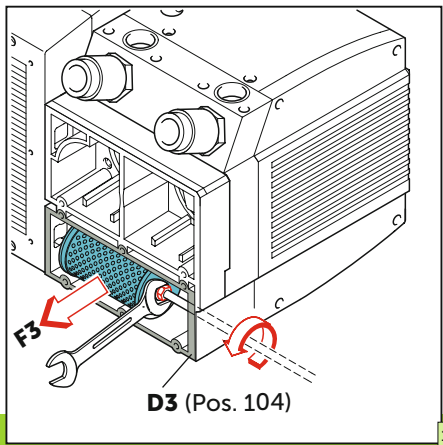

18

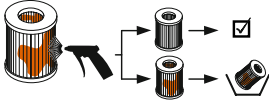
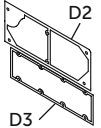
		
<p>EN149 - FFP3 42 CFR 84 - N100</p> 		
<p>F1 No.: 909507</p>	<p>F2 No.: 909506</p>	<p>F3 No.: 909510</p>
	<p>Satz / Kit Pos.: 17, 20, 24, 62, 75, 76, 85, 86, 104, 125, 126, 127, 146, 247, 248, 288 ▶ No.: 549002 21100</p>	

19

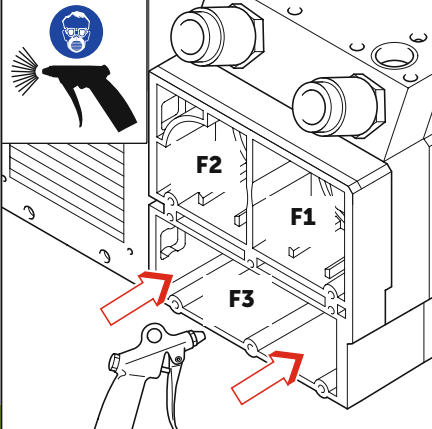

20

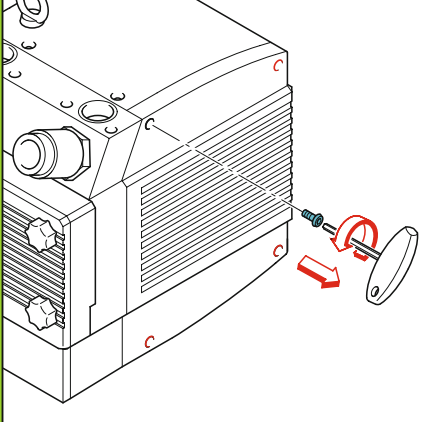

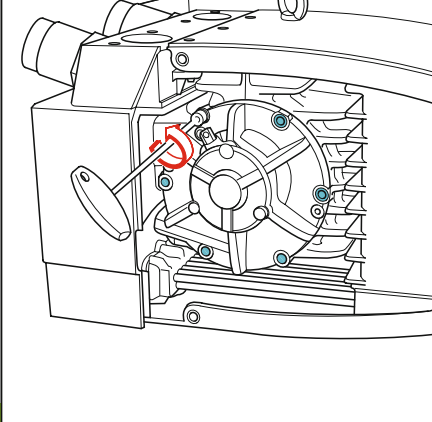

21

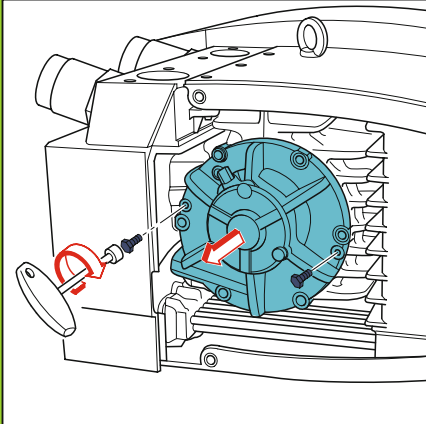

22

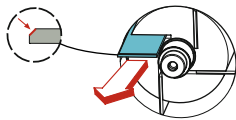
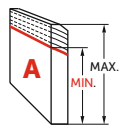
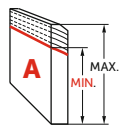

23

	
<p>3000 h</p>	
<p>$A_{MAX} = 38mm$ $A_{MIN} = 26mm$</p>	
<p>$A_{spr} < 26mm$</p>	
	<p>→ No. 9013300007 (SET)</p>

24

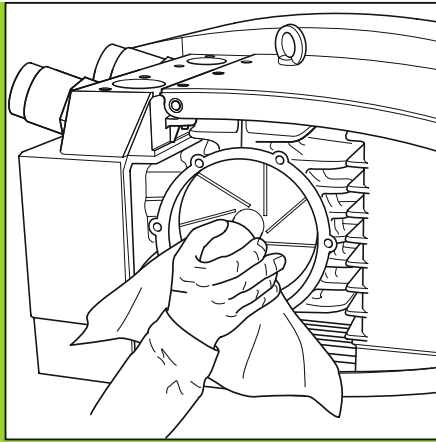

25

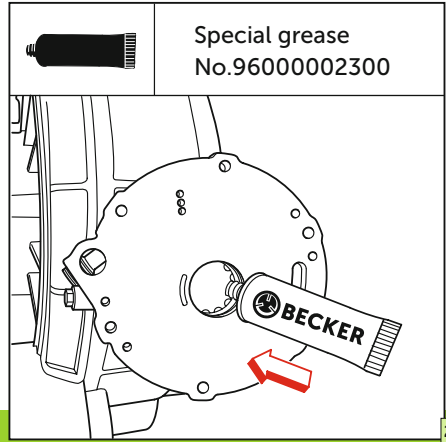

26

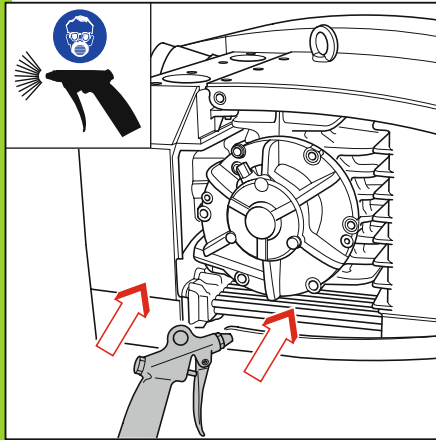

27

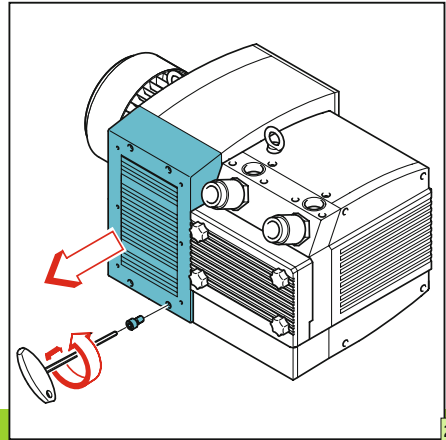

28

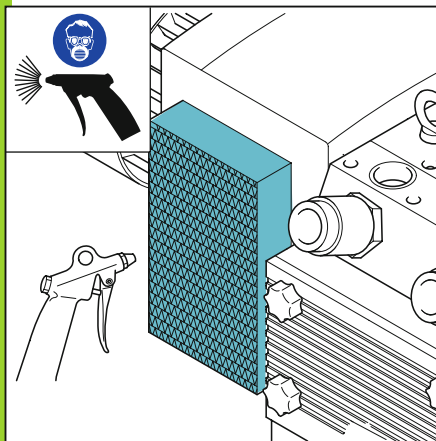

29

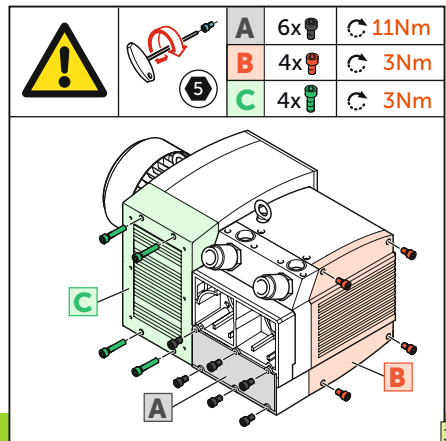

30

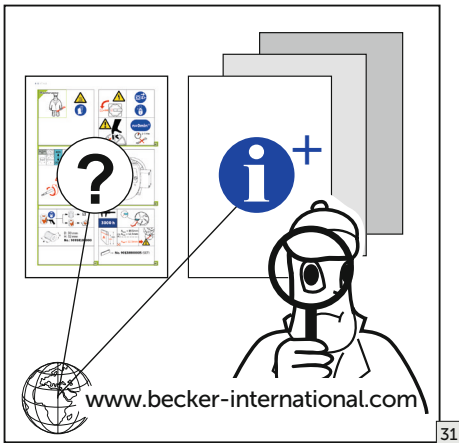

WWW.BECKER-INTERNATIONAL-SHOP.COM

Gebr. Becker GmbH
Hoelker Feld 29-31
42279 WUPPERTAL
GERMANY
info@becker-international.com
www.becker-international.com





MAKE IT BECKER.