

DATA SHEET

KVT 3.60

ROTARY VANE VACUUM PUMPS

oil-free

air-cooled

MAKE IT BECKER.

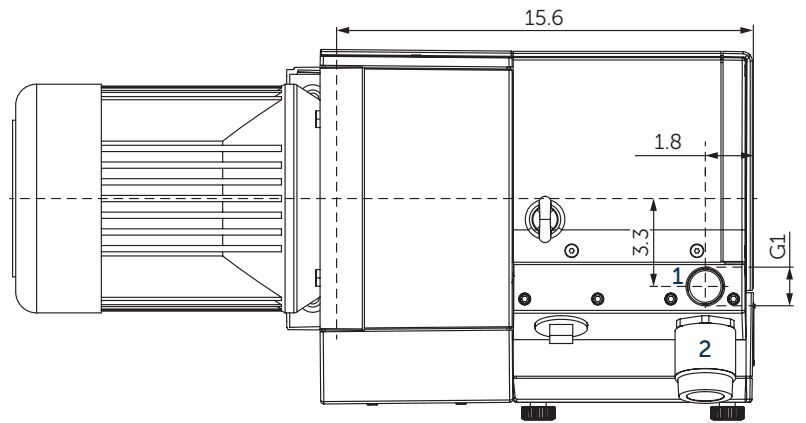
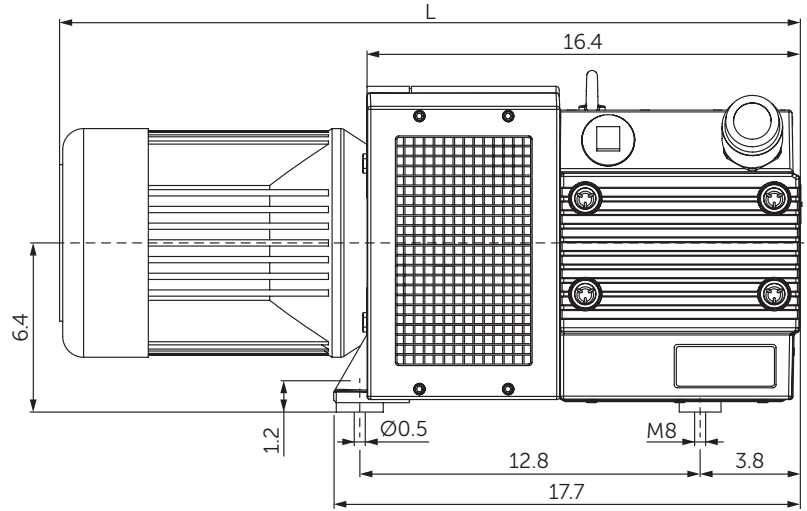
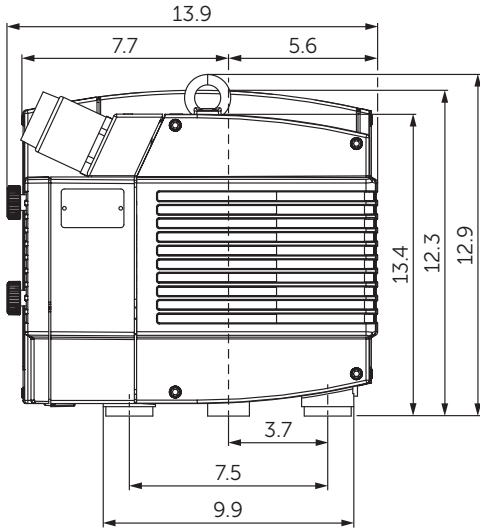

figure KVT 3.140

update
LTD

Authorized Dealer
1.800.229.0009
sales@updateitd.com
www.updateitd.com

 **BECKER**



- 1 Vacuum connection (G1)
- 2 Vacuum regulating valve
- Including integrated suction air filter and blow of valve
- The motor illustration may vary.
- Dimensions in inch

| Suction air rate | | Vacuum | | Emission sound pressure level ¹⁾ | | Weight w/o motor |
|------------------|-------|--------|-------|---|-------|------------------|
| 50 Hz | 60 Hz | 50 Hz | 60 Hz | 50 Hz | 60 Hz | lbs |
| 32 | 39 | 26.6 | 26.6 | 71 | 73 | 104 |

¹⁾ According to DIN EN ISO 3744 (KpA = 3 dB(A)), 39.4 inch distance, at medium load, both connection sides piped

| 3~ Motors ¹⁾ | | | | | | | | | | | | L | |
|-------------------------|-------|-----------|-----|------|----------|-------|---------------|-----|------|--------------|---|------|------|
| # | 50 Hz | | | | | 60 Hz | | | | Version | Weight lbs | inch | |
| | hp | V | IE3 | rpm | A | hp | V | IE3 | rpm | | | | A |
| 01 | 3.0 | Δ230/Y400 | IE3 | 1440 | 8.2/4.8 | 3.5 | Δ265/Y460 | IE3 | 1735 | 8.2/4.8 | IP55 • ISO F • bimetal | 54.0 | 27.7 |
| | | | | | | | Δ230/Y400 | | 1705 | 9.0/5.2 | | | |
| 02 | | | | | | 3.5 | YY230/Y460 | IE3 | 1763 | 9.3/4.6 | UL(E365362) • CSA CC334B IP55 • ISO F • bimetal | 81.6 | 29.4 |
| | | | | | | | YY208 | | 1754 | 9.7 | | | |
| 03 | 3.0 | Δ200/Y350 | IE3 | 1470 | 10.4/6.0 | 3.5 | Δ220/Y380-400 | IE3 | 1760 | 10.0/5.8–5.8 | UL(E365362) • CSA CC334B IP55 • ISO F • bimetal | 81.6 | 29.4 |
| | | | | | | | Δ200/Y350 | | 1755 | 10.2/5.9 | | | |
| 04 | | | | | | 3.5 | Δ400/Y690 | IE3 | 1760 | 5.3/3.1 | UL(E365362) • CSA CC334B IP55 • ISO F • bimetal | 81.6 | 29.4 |
| 05 | | | | | | 3.0 | YY230/Y460 | IE3 | 1800 | 8.0/4.0 | UL • CSA • NEMA ISO F | 95.0 | 28.5 |
| | | | | | | | YY208 | | 1730 | 8.8 | | | |

• Current consumption and rotation speed may vary. Tolerance in each case -1.5/+2%

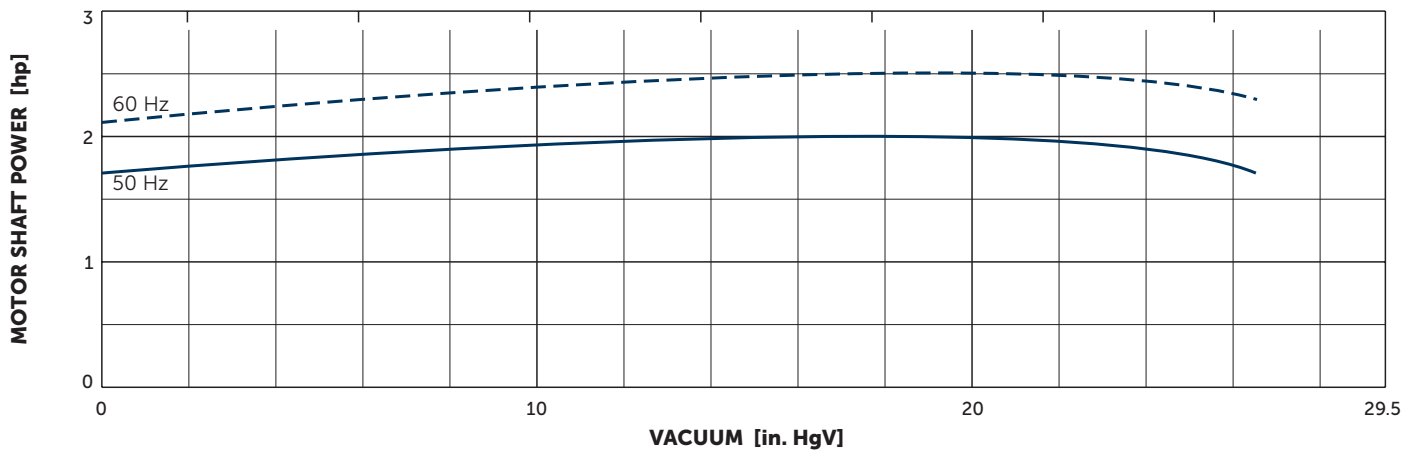
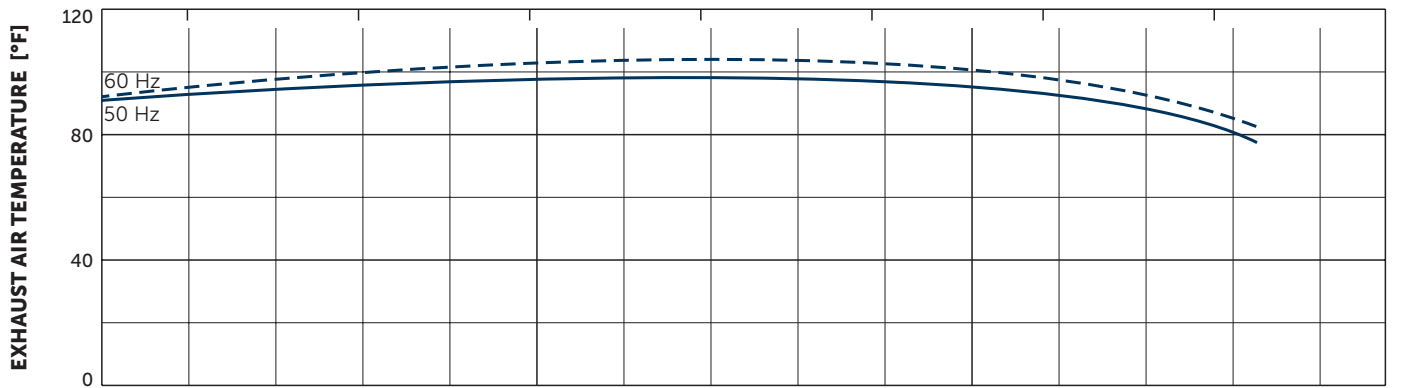
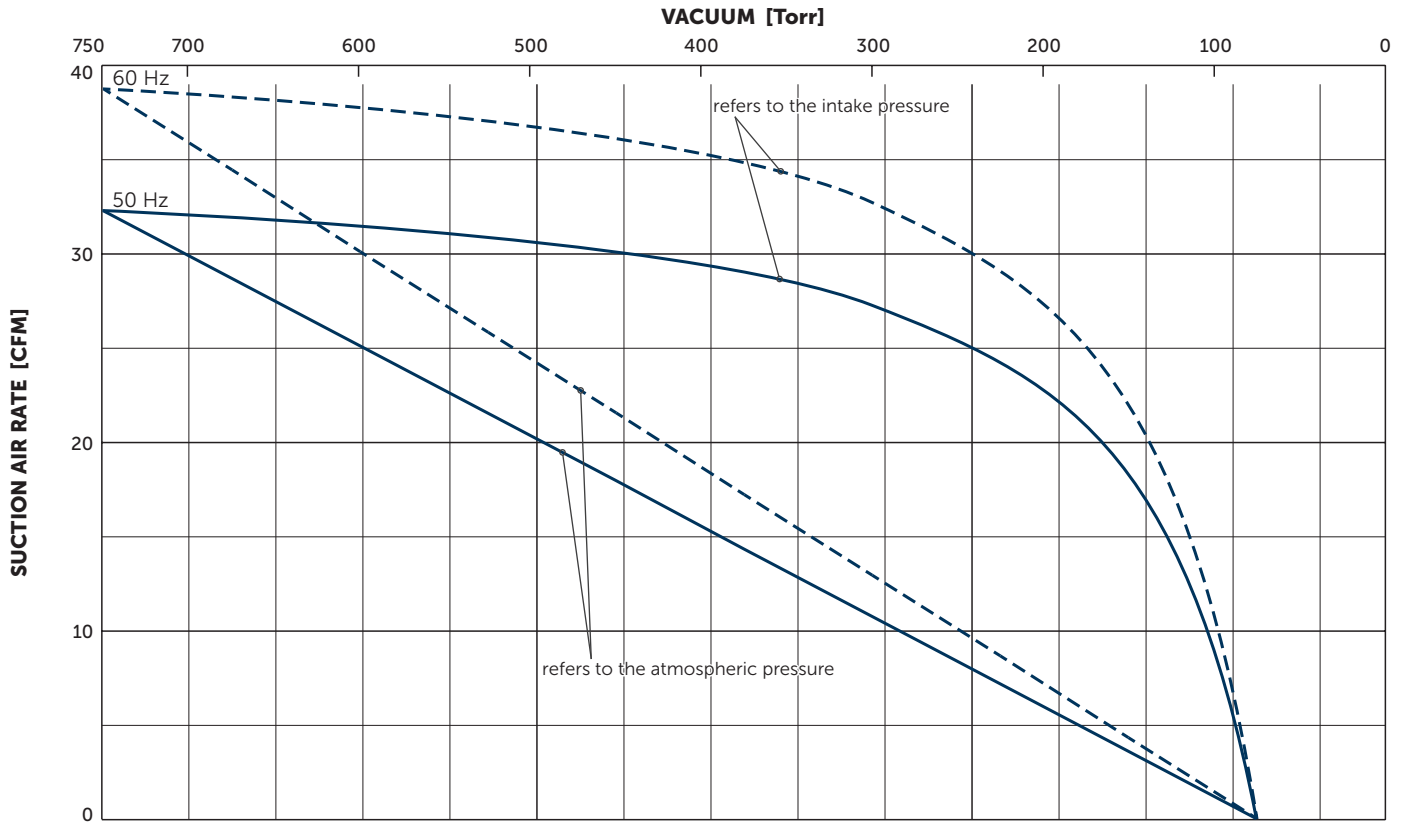

Reference data (atmosphere): 0 in. HgV, 68°F; Tolerance: ±5%

+ VARIANTS AND ACCESSORIES

KVX 3.60

SERIES X: BECKER INNOVATION WITH TOP WARRANTY

Equipped with specially developed vanes, these oil-free rotary vane pumps distinguish themselves by high abrasion resistance, and with that extremely long service lives. Due to the low wear there is also minimal dust, so the series X pumps are perfectly suited for precision processes under clean room conditions.

This innovation branded by Becker is outstanding not only because of its 100 percent oil-free operation, excellent degree of efficiency and low power consumption.

In the area of sensitive vacuum, series X also guarantees precise low-pulsation air conduction.

Becker guarantees for these pumps a vane life-time of 20,000 operating hours or a maximum of 3 years. The enhanced longevity of X series pumps also extends service life intervals, and can cut out the need for frequent service visits with costly pump failures now no longer an issue.



ADVANTAGES

- Quick, clean and quiet
- Oil-free
- Wear resistant
- Energy saving
- Long-life reliability

OTHER VARIANTS AND ACCESSORIES

- **KVT 3.60/0-54** with exhaust connection
- Increased corrosion protection
- External suction filter¹⁾
- Sound proof box SH 13¹⁾

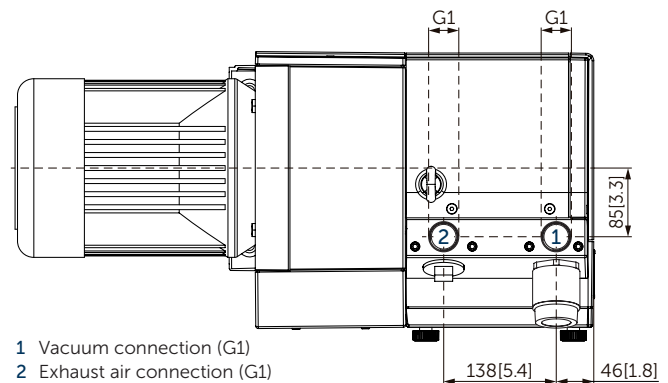

Example for an external suction filter



Sound proof box SH 13

¹⁾ See separate data sheet

- Possible combinations on request



MAKE IT BECKER.