



Hot-pressing device PT-300



The PT-300 is a hot-pressing device designed for joining Habasit driving and conveyor belts up to 300 mm wide and 8 mm thick, using the Thermofix procedure.

The heated bottom pressure plate is fitted with a removable setting plate with clamping bars for securely fixing the belt ends. The pressure is produced by means of a threaded spindle and torque wrench.

The hot-pressing device PT-300 is suitable for both workshop and portable use.

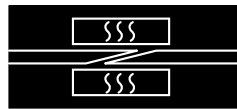

Contents:

1. General information 3

1.1 Area of application 3

1.2 Important safety terms 3

1.3 Scope of supply..... 4

1.3.1 Available accessories 4

1.4 Ordering of accessories / spare parts..... 5

1.5 Warranty..... 5

1.6 Technical advice 5

2. Mode of operation 6

3. Initial start-up 6

4. Hot-pressing conveyor/driving belts 7

5. Service..... 8

5.1 Maintenance..... 8

5.2 Measuring the temperature..... 8

6. Illustrations 9

7. Technical data 11

8. Drawings 12

8.1 Electrical connection 12

8.2 Setting plate with spares numbers..... 12

8.3 Assembly drawing and spares numbers..... 13

Appendix

- Checklist; preventive maintenance
- Report sheet for preventive maintenance
- Product liability, application considerations

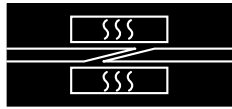

1. General information

1.1 Area of application

Hot-pressing device PT-300 was specifically designed for the rapid and safe hot-pressing of Thermofix joins for Habasit driving and conveyor belts up to a width of 300 mm (right-angle skiving, 90°), respectively width 250 mm (75° diagonal) and width 200 mm (60° diagonal).

The maximum belt thickness is 8 mm.

The press is suitable for both stationary and portable use.

The PT-300 hot-pressing device was developed solely for the purposes described in the operating instructions. Improper use, or use for other purposes than those described in the instructions, is not permissible. Habasit accepts no liability for the consequences of improper application. Hot-pressing device PT-300 is manufactured according to recognized engineering principles and state-of-the-art technology, and complies with applicable regulations.

It is assumed that all assembly, maintenance, and repair work, as well as operation, is performed by qualified tradesmen or is supervised by responsible specialists.

Due to spatial considerations, these instructions cannot cover all possible aspects of operation, maintenance, or repair. The indications given here refer to the use of the machines for their designated purpose by qualified persons.

In case of doubt or if further detailed information is required, please consult the manufacturer (chapter 1.4).

1.2 Important safety terms

In these operating instructions you will find the terms WARNING, CAUTION, and NOTE. They signify dangers or special information which is to be borne in mind.

WARNING If disregarded, there is a danger of serious physical injury and/or major damage to property.

CAUTION If disregarded, there is a danger of injury and/or damage to the equipment.

NOTE Important technical information is emphasized where such details are not readily apparent, even for skilled personnel.

Please observe all instructions for assembling, operating, and maintaining the machines, as well as all technical data! This will prevent possible trouble and/or damage to persons or property.

The term “skilled personnel” refers to persons authorized to perform the required work. These individuals have received the necessary basic training and have been introduced to their field of activity so that they are able to recognize and avoid dangers. They are familiar with the relevant provisions and safety regulations.

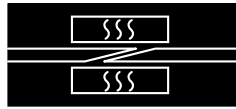

1.3 Scope of supply

- PT-300/6: Under this designation, the hot-pressing device for **120V** is fitted with a mains cable with a US connector plug.
- PT-300/7 Under this designation, the hot-pressing device for **230V** is fitted with a mains cable for Switzerland.
- PT-300/8 Under this designation the hot-pressing device for **230V** is fitted with a mains cable with a European connector plug.
- Delivery: PT-300 hot-pressing device with operating instructions packed in a carton.

Quantity		Order No.
1	PT-300	see above
1	Torque wrench	N-21882
1	Socket with internal 14 mm hex key.	N-21702
1	Mains connector cable (loose)	

1.3.1 Available accessories

Accessories	Order No..
1 Pair of gloves	N-29090
1 Temperature measuring device	N-28714 or N-28715



1.4 Ordering of accessories / spare parts

Spare parts and accessories can be ordered directly from the manufacturer.

Address:

Habasit Italiana S.p.A.
Via A. Meucci 8, Zona Industriale
I-31029 Vittorio Veneto/TV
Tel. ++39 438 91 13
Fax ++39 438 91 2374

Identify the relevant spare part numbers according to drawings (sections 8.2 and 8.3), designation and, where applicable, the connection voltage for the mains supply.

WARNING	The use of non-Habasit parts not meeting Habasit specifications is not permitted. Habasit declines all responsibility for the consequences if non-Habasit parts are used.
----------------	---

1.5 Warranty

All tools undergo a strict final inspection. On the assumption of correct handling, they are warranted against material and manufacturing defects for 1 year.

1.6 Technical advice

Our specialists will be pleased to advise you. For technical questions concerning function and condition of the hot-pressing device, please contact the manufacturer (see Chapter 1.4 for the address).

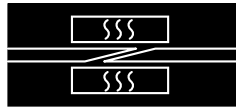

2. Mode of operation

Hot-pressing device PT-300 operates with a pressing temperature of 100 °C or 120 °C, preset at the factory. A heater plate (13) and a temperature sensor are incorporated in the press lower part (4). The setting plate (3) with lateral clamping bars (5) is screw mounted to the heater plate. Eight sets of resilient disks under the heater plate (13) ensure a uniform pressure distribution. For placing the driving/conveyor belt in position, the press upper part (2) with integrated pressure plate (1) is swung back against a hinge stop (12). For portable use it can be removed completely. The pressing force is generated by a threaded spindle (6) which can be raised and set with a torque wrench.

3. Initial start-up

- Check to make sure that the voltage indicated on the rating plate (8) conforms to the actual mains voltage.
- Place the hot-pressing device on a stable, heat-resistant support.
- Check that the setting plate (3) and the pressure plate (1) are clean.

NOTE

Threaded holes are located on the underside of the housing.
For safe operation, the hot-pressing device can be screw mounted to a bench/frame.

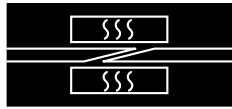

4. Hot-pressing conveyor/driving belts

Process: Thermofix guidelines 3210 and individual product datasheets.

- Release threaded spindle (6) and fold forward, swing press upper part (2) back onto the hinge stop (12). The press upper part (2) can be folded right back to the rear by withdrawing the bottom hinge pin (14) and raising the press upper part (2) together with the hinge stop (12). The press upper part (2) can also be completely removed by withdrawing the top hinge pin (11).
- Release and open the left and right clamping bars (5). Place the prepared driving/conveyor belt end on the setting plate (3) with the skived surface upwards, centered exactly at right-angles. Fix in position with the appropriate clamping bar (5). Place the other end over it, exactly aligned, and fix in position with the other clamping bar (5).

NOTE	Adhesive is only to be applied outside the hot-pressing device.
-------------	---

- Depending on how the press has been opened, re-insert the bottom pin (14) for the hinge stop (12), respectively the top pin (11) for the press upper part (2) and close the press. Fold up the threaded spindle (6) and tighten first by hand, then with the supplied torque wrench to a torque setting of 17 Nm.

WARNING	The torque of 17 Nm is not to be exceeded → Material damage.
----------------	---

- Insert the mains supply connector plug and set the product-specific pressing temperature at the temperature switch (7). The relevant nominal temperature lamp (10) lights. The heating up of the press is indicated by the lighting of the thermostat lamp (9).

CAUTION	Press components are hot. Do not touch the surfaces without wearing protective clothing. Always wear protective gloves. Do not allow water and meltable substances to come into contact with the press.
----------------	---

- After approx. 12 minutes heating-up time, the set pressing temperature is reached and the thermostat lamp (9) goes out. The pressing time commences.

NOTE	The dwell time (heating-up plus pressing time) of the conveyor/driving belt in the pressing device must be observed. If the dwell time is significantly exceeded, the pressing temperature can rise by up to 12 °C above the set nominal temperature (7).
-------------	--

- After the expiry of the pressing time, pull out the mains connector plug and allow the pressing device to cool down in the closed state for approx. 10 minutes.
- Open the hot-pressing device (see above), take out the conveyor/driving belt and leave to cool down for a few minutes.

WARNING	Allow the hot-pressing device to fully cool down before it is repacked.
----------------	---

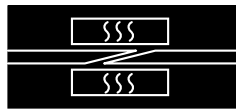

5. Service

5.1 Maintenance

- ❑ Keep the hot-pressing device clean at all times. Clean the pressing (1) and setting (3) plates regularly and remove all material residues.

WARNING	For cleaning with a cloth moistened with water or solvent, the press must be disconnected from the mains supply. Do not reconnect to the mains supply until the press is completely dry.
----------------	---

- ❑ Periodically inspect the mains supply cable and connector plug for defects (insulation damage, etc.) and where necessary rectify or replace by the correct type.

5.2 Measuring the temperature

Check the operating temperature of the hot-pressing device once a month.

- ❑ Carry out this check in an interior room in a draft-free environment with an ambient temperature of between 18 and 25 °C.
- ❑ Place the temperature sensor of a measuring device on the setting plate (3) and cover with a heat-resistant silicon-foam rubber mat.
- ❑ Close the press without applying clamping force (utilize only the weight of the press upper part itself) and leave to heat up for 15 minutes.
- ❑ The operating temperature is reached when the thermostat lamp (9) goes out.
- ❑ The temperature measuring device should not deviate by more than $\pm 8\text{ °C}$ / $\pm 14\text{ °F}$ from 100 °C / 212 °F, resp. 120 °C / 248 °F.

INDICATION	If the measured temperature deviates from the maximum or minimum value, the heating element must be replaced at the factory.
-------------------	--



Fig. 1: Measurement of the heater plate temperature

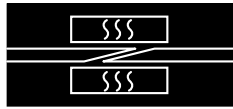

6. Illustrations

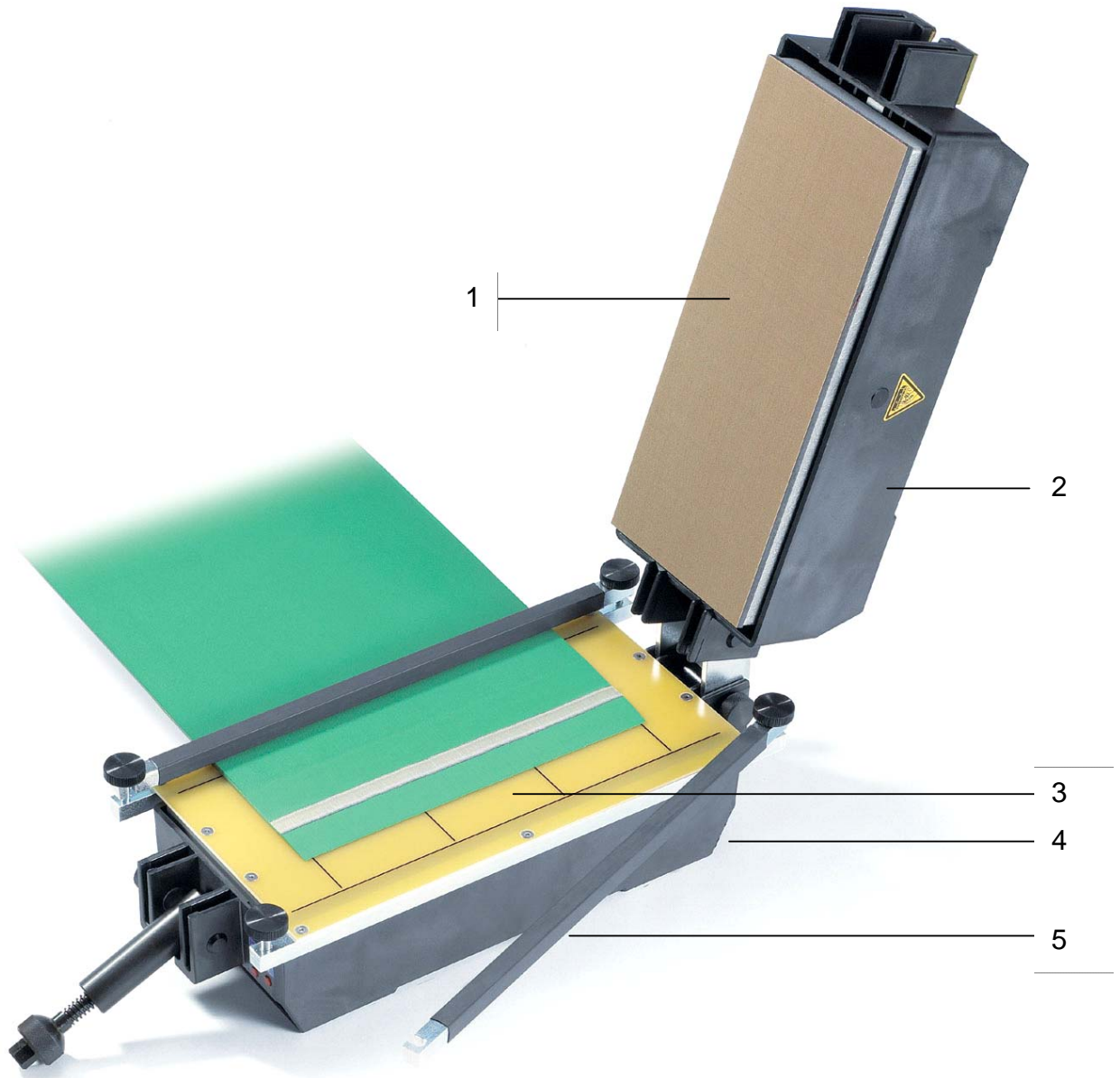

Fig. 2 Press opened

- 1 Pressure plate
- 2 Press upper part
- 3 Setting plate
- 4 Press lower part
- 5 Clamping bar

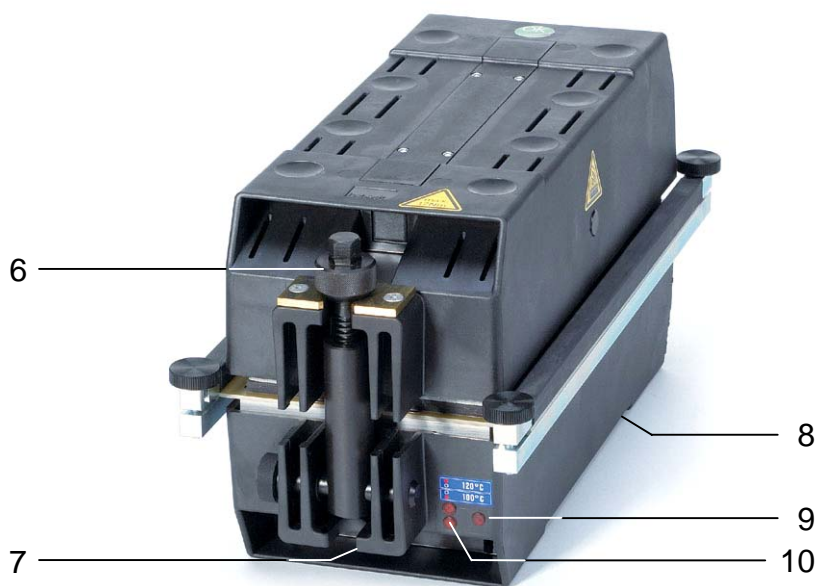

Fig. 3 Press front

- | | | | |
|---|--------------------|----|--------------------------|
| 6 | Threaded spindle | 9 | Thermostat lamp |
| 7 | Temperature switch | 10 | Nominal temperature lamp |
| 8 | Rating plate | | |

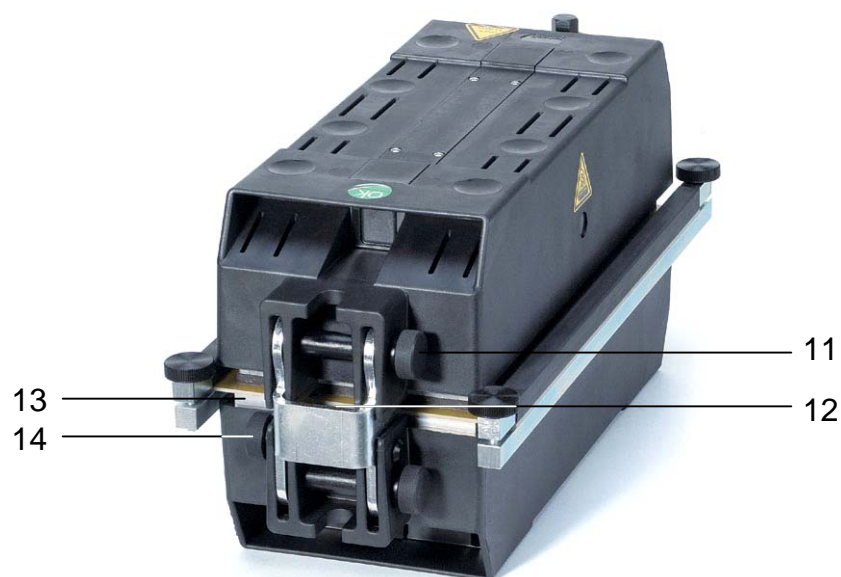

Fig. 4 Press rear

- | | | | |
|----|---------------|----|------------------|
| 11 | Top hinge pin | 13 | Heater plate |
| 12 | Hinge stop | 14 | Bottom hinge pin |



7. Technical data

Max. belt/tape width [mm] [<i>in.</i>] with 90° joining angle	300	12
Max. belt/tape width [mm] [<i>in.</i>] with 75° joining angle	250	10
Max. belt/tape width [mm] [<i>in.</i>] with 60° joining angle	200	8
Max. belt/tape thickness [mm] [<i>in.</i>]	8	0.31
Max. skiving length [mm] [<i>in.</i>]	110	4.33
Min. continuous belt/tape length [mm] [<i>in.</i>]	250	10
Power consumption [W]	800	
Voltage [V~]	120 / 230	
Dimensions (L x W x H) [mm] [<i>in.</i>]	420 x 175 x 200	16.5 x 6.9 x 7.9
Net weight [kg] [<i>lbs.</i>]	12	26.5

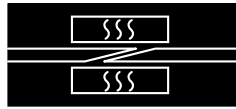

8. Drawings

8.1 Electrical connection

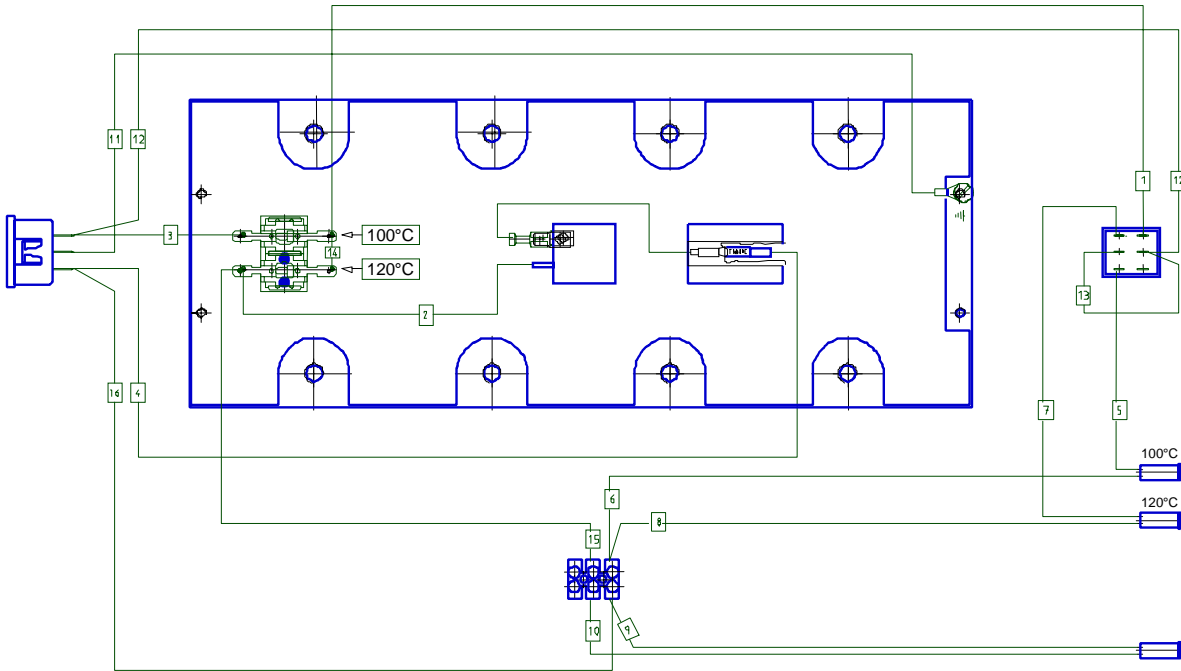

8.2 Setting plate with spares numbers

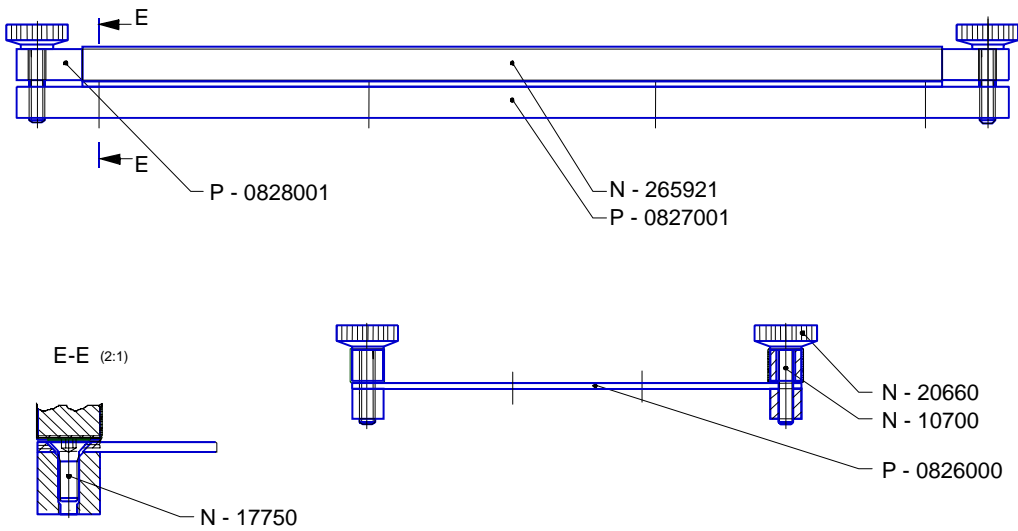

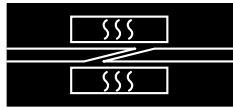

8.3 Assembly drawing and spares numbers

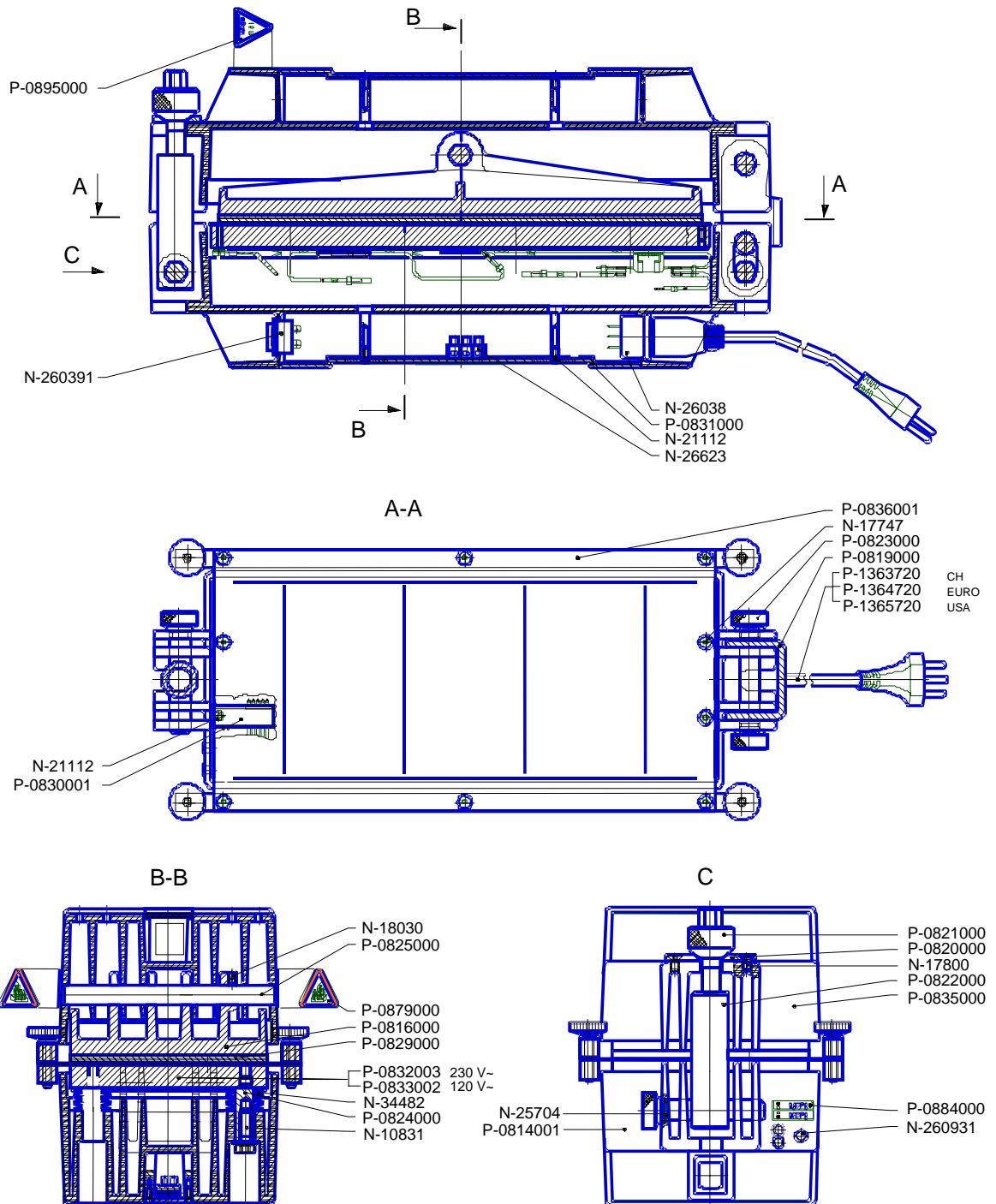

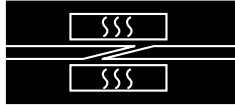

Checklist for preventive maintenance
Hot-pressing device PT-300



Edition: 03/0310

Responsible persons: **A:** **Machine operator**
 B: **Maintenance personnel**

Work to be carried out (see operating instructions No. 3628 for further information and reference numbers)	Daily	Performance periodically (monthly)			Spares number Evaluation criterion
		1	6	Remarks	
1. Cleaning					
1.1 Clean the press after use, remove residual deposits	A				
2. Inspect the connector cable					
2.1 Examine the cable and connector plug for defects		B			damaged insulation, defective couplings
3. Measurement of the heater plate temperature					
3.1 Proceed as detailed in operating instructions 3628, section 5.2		B			

Remarks and notes:



Machine type:

Machine no.:

Date of first placing in operation:

Actions to be performed – see checklist (daily work not recorded)	Next	Performed		Next	Performed		Next	Performed		Next	Performed	
	Check	Initials	Date	Check	Initials	Date	Check	Initials	Date	Check	Initials	Date
2.1 Inspect the cable for damage												
3.1 Measure the heater plate temperature												

Observations, repairs:

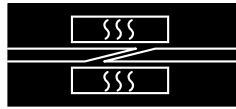

Product liability, application considerations

If the proper selection and application of Habasit products are not recommended by an authorized Habasit sales specialist, the selection and application of Habasit products, including the related area of product safety, are the responsibility of the customer.

All indications / information are recommendations and believed to be reliable, but no representations, guarantees, or warranties of any kind are made as to their accuracy or suitability for particular applications. The data provided herein are based on laboratory work with small-scale test equipment, running at standard conditions, and do not necessarily match product performance in industrial use. New knowledge and experiences can lead to modifications and changes within a short time without prior notice.

BECAUSE CONDITIONS OF USE ARE OUTSIDE OF HABASIT'S AND ITS AFFILIATED COMPANIES CONTROL, WE CANNOT ASSUME ANY LIABILITY CONCERNING THE SUITABILITY AND PROCESS ABILITY OF THE PRODUCTS MENTIONED HEREIN. THIS ALSO APPLIES TO PROCESS RESULTS / OUTPUT / MANUFACTURING GOODS AS WELL AS TO POSSIBLE DEFECTS, DAMAGES, CONSEQUENTIAL DAMAGES, AND FURTHER-REACHING CONSEQUENCES.
