

### Item List:

- 1-TSC\_Edge 1- SmartCount Edge™
- 1- Power cable (12V )
- 1-HDMI10 1- 10' HDMI cable
- 1-UPR 1- 65" Extrusion piece with End Fastener
- 1- 24" Extrusion piece
- 3- 11" Extrusion piece with End Fasteners
- 1- Hardware Bag
- 1- Tool Kit
- 1-TVBCKT 1- Boxed Swivel Bracket Mount
- 1- Hardware Bag
- 1-MSE/TRAY 1- Aluminum Tray
- 1- Mouse Pad
- 1- Hardware Bag
- 1-MSE 1- Wired USB Mouse
- (T1) 1-TV24 1- 24" TV
- or (T2) 1-TV21 1- 21" Touchscreen



### UPR - Assembly

On the 65" extrusion piece loosen the end fastener screw slightly so there is play with the end fastener. Attach the 65" to the 24" by aligning the screw head into the extrusion channel. Make sure to align to the channel containing 1 hole at the mid-point. Align the screw head to the hole and with a 3/16" align tighten the screw. (Fig. 1)

Repeat the same process using 2 - 11" pieces to create the leg-posts. These will align with the 24" extrusion channel containing 2 holes. Position one leg opposite the other. Align and tighten. Install end caps. *If the wheel options were ordered then hold off from installing the extrusion end caps until the wheels are mounted. Reference page 2 for wheel installation.*

Repeat the same process for the remaining 11" piece to create the SC Edge arm. This will align with the 65" extrusion channel containing 1 hole 16" down from the top. Align and tighten. Install end caps (Fig. 2)

Drop in the T-nuts from hardware bag into extrusion slot as shown (Fig. 3) Align the SmartCount Edge™ side mount flanges to the T-nuts and install the screws. Align horizontally and tighten.

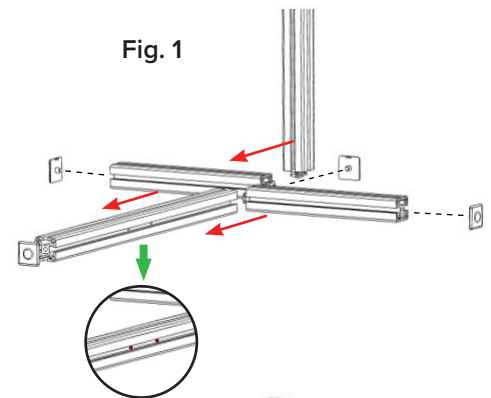

Fig. 1

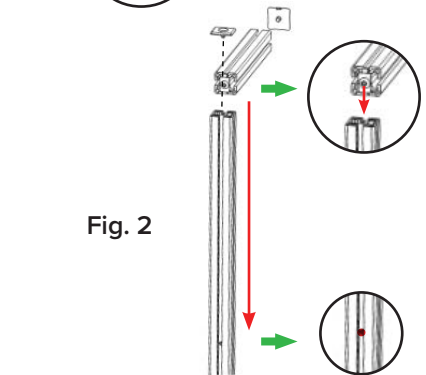

Fig. 2

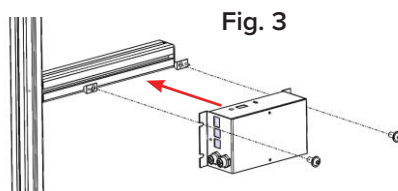

Fig. 3

## TVBCKT Assembly

Assemble the display bracket (Fig. 4 -Dark shading) to the TV24 (or TV21) using the provided screws in the bracket carton. Install the swivel bracket (Fig. 4 - Light shading) to the extrusion using the hardware provided in the TVBCKT hardware bag.

Hang the TV, with display bracket attached and secure using the 2 security screws. Connect TV power cord and connect HDMI cable to SmartCount Edge™.

*Note: If T2 assembly was ordered, there will be an additional USB cable to connect the touchscreen to the SC Edge. This cable will be found with the TV21 packaging*

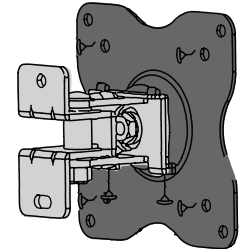

Fig. 4

## MSE/TRAY Assembly

Assemble the tray to the 90° bracket using the hardware provided in the MSE/TRAY hardware bag. Ensure the washer is installed between the tray and bracket as shown in (Fig. 5.)

Position the T-nut into the extrusion channel and adjust to the desired tray height. Attached assemble tray to the T-nut and tighten.

Connect the MSE to the SmartCount Edge™.

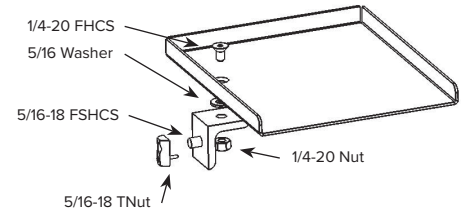

Fig. 5

**AT THIS POINT YOUR ASSEMBLY IS COMPLETE. YOU WILL NEED TO CONNECT WHATEVER COUNT INPUT (Sensor, Pushbutton, Encoder, etc.) TO THE SC Edge M12-A INPUT**

## (Optional) UPRB Assembly

- 1-UPRB 4 - Roller Wheel Assemblies
- 4 - Extrusion end caps

Slide the base wheel onto the upright leg extension. (Fig. 6)

*Note: if FT-UPRB option was ordered after the time of building the FT-UPR, then removal of the end caps will be required before inserting the wheel assembly.*

Secure the wheel in place by tightening the screw noted in (Fig. 6.) Install end cap and repeat for the other wheels.

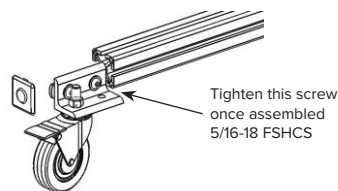

Fig. 6

