

SB-2/3EX

Standard & Stainless

**Industrial
Case Taping System**

User Guide

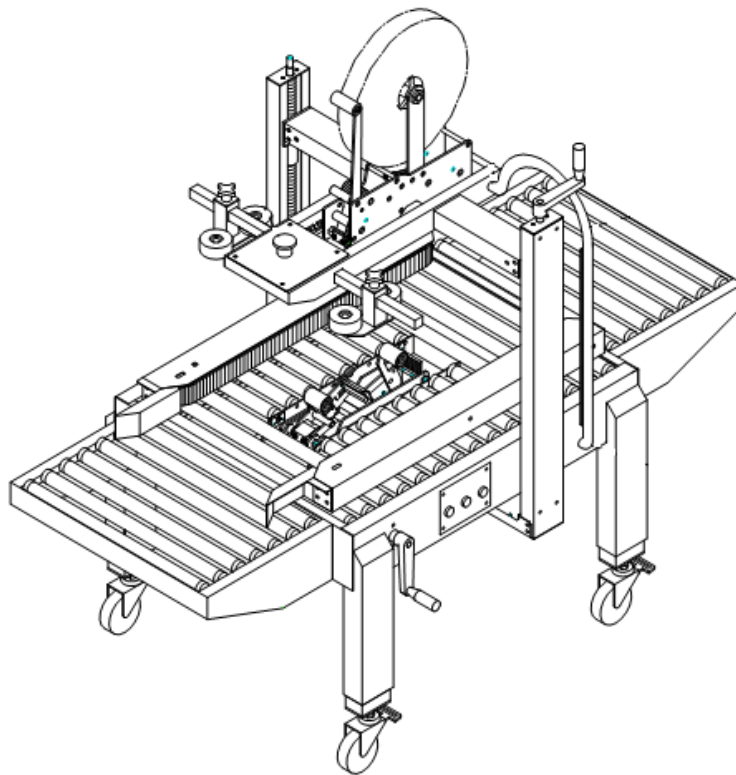

update
LTD

www.update ltd.com
1-800-229-0009

EASTEY[®]

SB-2/3EX

Standard & Stainless

Industrial Case Taping System

User Guide

Revised 10/15/2015

P/N 5001680 Rev D

Copyright and Trademarks

Copyright ©2013-2015 Eastey Enterprises
All rights reserved. All trademarks and registered names
are the property of their respective owners.

Eastey Enterprises, Inc.
7041 Boone Ave. N
Brooklyn Park, MN 55428

Phone: (763) 428-4846; Fax (763) 795-8867; 1-800-877-9344

www.eastey.com

Contents:

- Safety 7**
- Introduction 8**
 - General System Description..... 8
 - Specifications 9
 - Options..... 9
 - Dimensions 10
- Installation 11**
 - Location Requirements 12
 - Install Front and Rear Tables 13
 - Next Steps..... 13
- Operation 15**
 - Loading the Tape Cartridges..... 15
 - Check Tension 16
 - Thread Tape..... 16
 - Center Tape — Eastey-EX Tape Head only 18
 - Main Spring..... 18
 - Power 19
 - Control Panel 19
 - Emergency Stop..... 20
- Adjustments 21**
 - Carton Height and Width Adjustments..... 21
 - Belt Adjustment 23
 - Machine Body Height Adjustment 23
- Maintenance 25**
 - Rollers..... 25
 - Cutting Knives 25
- Troubleshooting 27**
- Parts List..... 29**
 - Electrical..... 29
 - Side Belt Assembly 33
 - Side Belt Assembly (Stainless) 36
 - Vertical Column..... 38
 - Vertical Column (Stainless) 41
 - Machine Body 43
 - Machine Body (Stainless)..... 45
- Warranty Statement 47**
- Customer Support..... 49**

Safety

Before installing, operating or servicing this equipment, please read the following precautions carefully:

- This machine is equipped with moving belts. Do not place hands near the rear of this unit when the belts are moving as fingers may be pinched where belts enter the frame. We suggest the use of a roller-type exit conveyor or pack table for your cases. Always remove boxes after they clear the exit end of the machine.
- Observe caution when near the tape applying cartridges or when threading tape. The knife is very sharp, automatically operated and is linked to the wipe down rollers.
- Do not attempt to open or work on the electrical box, junction boxes or other electrical components of the unit without first disconnecting power to the machine. Electrical shock hazard exists if power is not disconnected.
- Do not by-pass any factory-designed safety features such as knife guards, interlocks, switches, etc.
- Do not place hands or body inside the confines of the machine unless the head mechanism is securely fastened, and the electrical supply is shut off.
- Never provide service or clear a box jam when machine is running.
- When feeding a box into the unit, always hold down the box top and present the box to unit. Release hands as soon as the belts begin to take the box.
- Do not wear loose clothing such as ties, scarves, jewelry etc. Long hair should be pulled back and/or covered while operating this machine.

Introduction

General System Description

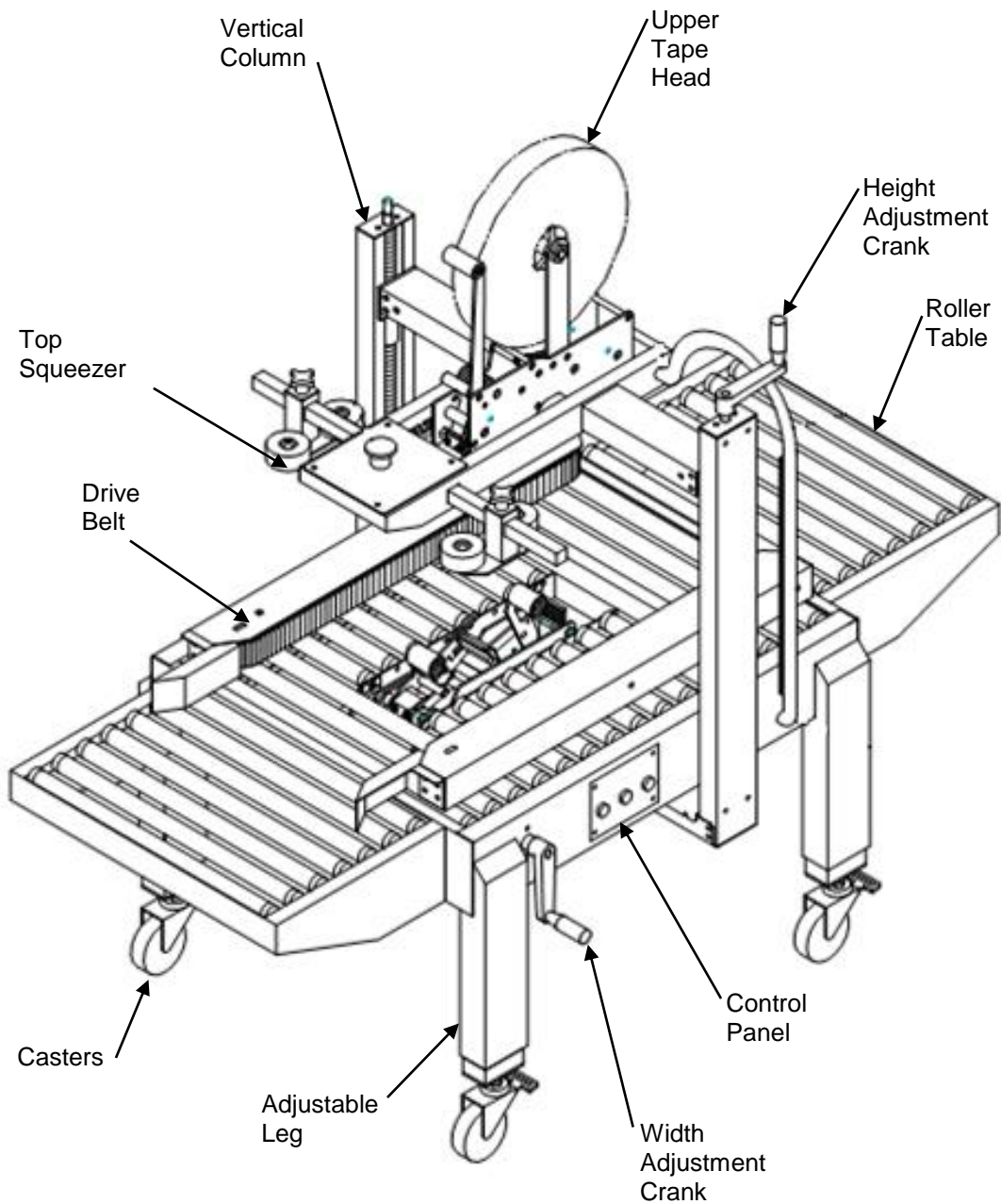

Specifications

Model	SB-2/3EX Standard
Tape	1.5 inches (3.6 cm) or 2 inches (5 cm), up to 15 inches (36 cm) diameter rolls
Belt speed	75.5 feet/min. (23 m/min.)
Capacity	(L) 4.7 inches (12 cm) to unlimited (W) 3.9 inches to 19.5 inches (10 cm to 50 cm) (H) 4.7 inches to 19.5 inches (12 cm to 50 cm)
Power Consumption	450W
Machine size	(L) 68 inches (173 cm) (W) 33.6 inches (85 cm) (H) 63.1 inches (160 cm) w/o tape head (H) 70 inches (178 cm) with max. tape roll
Machine net weight	353lbs (160kg)

Options

- Stainless Steel
- 3" tape head

Dimensions

Dimensions are shown in inches.

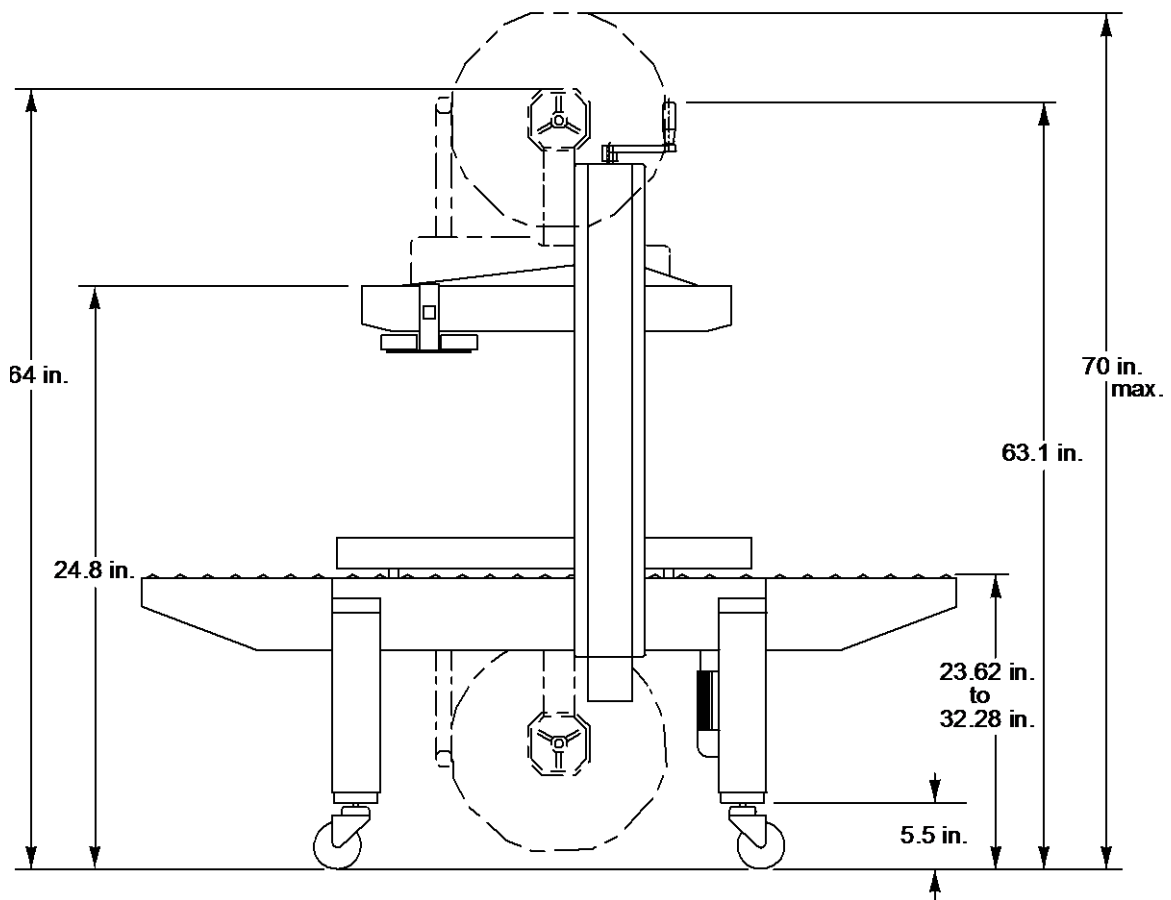
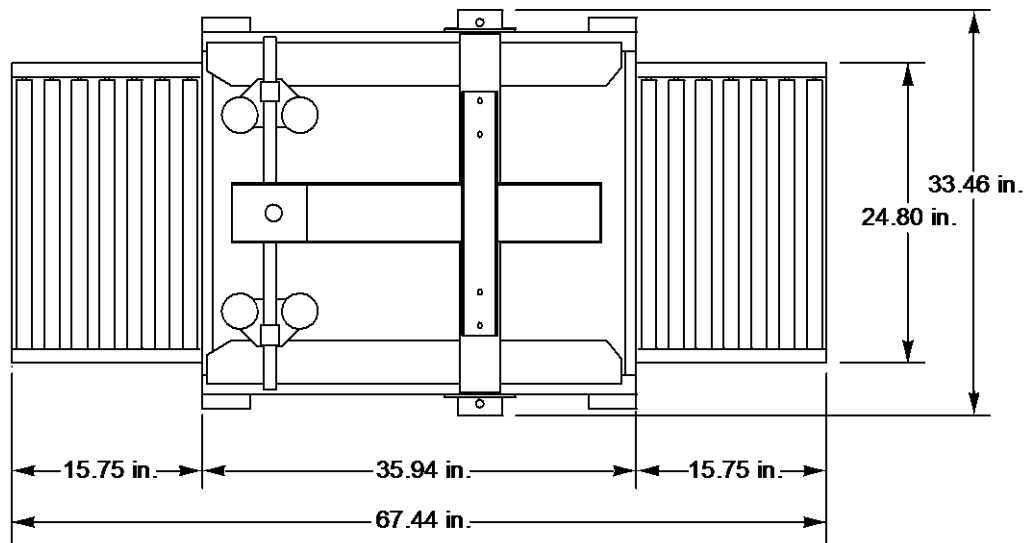

Installation

Carefully unpack the case taper from the shipping carton.

Remove the shipping bolts that secure the Case Taper to the shipping pallet. Lift the Case Taper off the pallet.

CAUTION! The SB-2/3EX Standard Case Taper is very heavy and will require a forklift, floor crane, or several people to move safely off the shipping pallet. Use proper equipment when lifting the case taper and ensure the case taper is secure and will not shift while being moved or during height adjustment or installation of optional locking casters.

Install the four (4) casters on the Case Taper legs. The casters are very easy to install simply screw into the threaded holes on the bottom of each leg.

To adjust the leg height, loosen the screws on each leg and slide the insert up or down. When the leg is at the desired height, retighten the adjustment screws to secure the leg height.

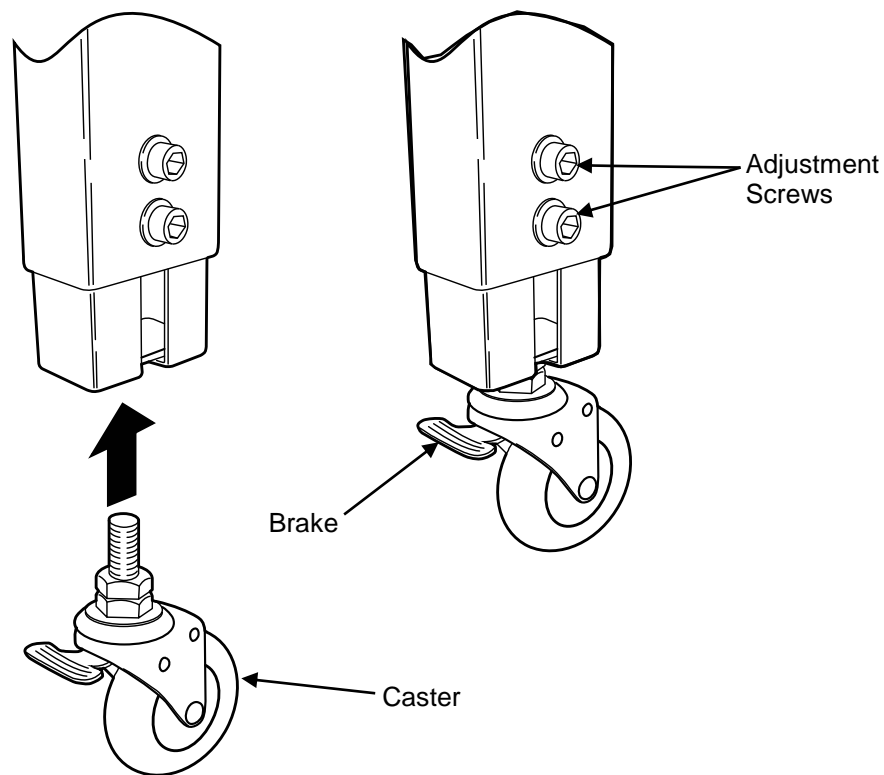

CAUTION! The case taper must be lifted off the floor to install the casters. Use proper equipment when lifting or moving the case taper. Ensure the case taper is secure and will not shift while installing the casters or adjusting leg height.

The locking casters allow the taper to be moved easily over a smooth flat surface. If the unit must be lifted to move it to the desired location you will need to use a pallet jack, floor crane, or fork lift to lift it.

Location Requirements

When installing the SB-2/3EX Standard Case Taper please be aware of the following considerations:

1. The mounting surface is flat and level.
2. Conveyor or packing table height.
3. Alignment with packaging line.

When the SB 2/3-EX Standard Case Taper is positioned in the operating location you will need access to:

1. The power switch.
2. Height and width adjustments.
3. Tape loading (Both upper and lower tape cartridges).

Roller tables are provided standard at both the in-feed and exit ends of the case taper. A packer can fill boxes and close the flaps at the in-feed roller table before feeding boxes into the case taper, and then pick up boxes that have been sealed from the exit roller table.

If the case taper is part of a longer packaging line, take into consideration the table and conveyor height in relation to adjacent machinery.

It is essential that the table and conveyor be at the machine bed height.

The machine should be placed on a flat, level floor so that it does not rock or move. We recommend that the machine be securely locked in place when used.

Install Front and Rear Tables

Front and rear tables are identical and therefore interchangeable. Temporarily loosen socket head cap screws at the locations shown in the following illustration. Align the keyhole slots in the table flanges with the loosened cap screw heads and position the end table so rollers are level with rollers in the case taper body, then re-tighten cap screws to secure table. Install one table at each end (front and rear) of the case taper body.

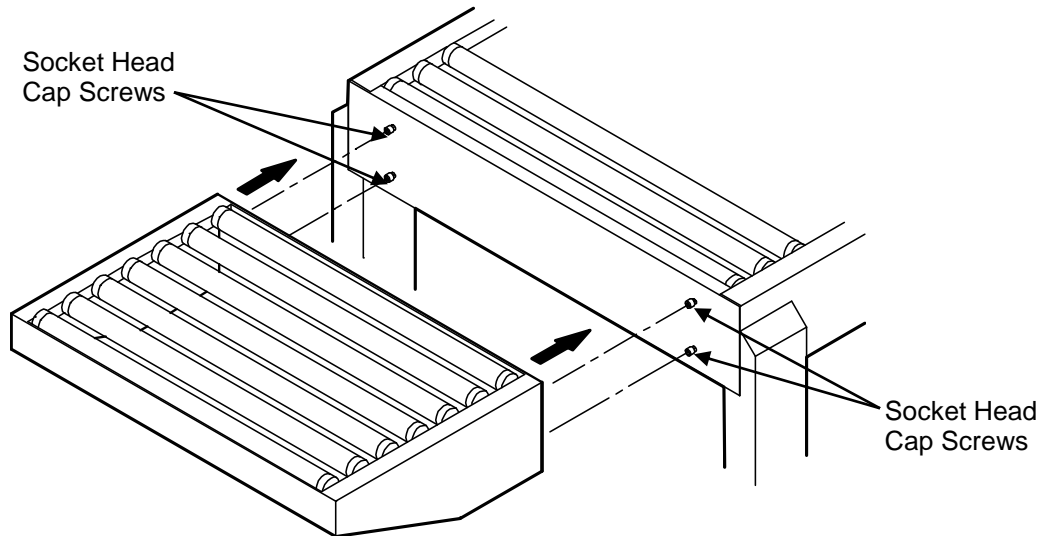

Next Steps

Follow instructions in the Operation section for instructions to load the tape cartridges in the upper and lower tape heads.

If tape heads have not been loaded with tape, load the upper and lower tape heads with tape. (One roll each; follow instructions provided in the Tape Cartridge User Guide.)

Refer to the Adjustments section for instructions to make necessary height and width adjustments that must be made for operation of the box taper.

Refer to the Operation section for instructions to power up, operate, and shut down the machine.

Operation

Loading the Tape Cartridges

Turn the main power switch to “Off” and disconnect the power.

CAUTION! To avoid personnel injury, remove the tape cartridge before loading tape.

When handling the tape cartridge be careful to avoid contact with the tape cutting blade.

After the taping cartridge has been removed push the tape roll onto the tape core assembly.

NOTE: Make sure the tape roll is pushed all the way on the spindle assembly.

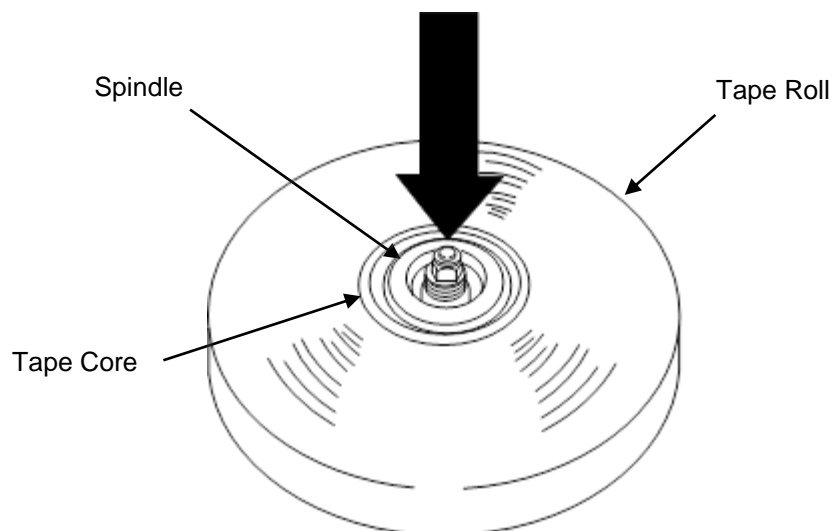

Check Tension

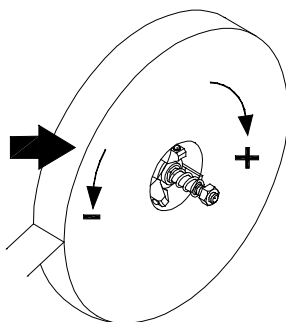
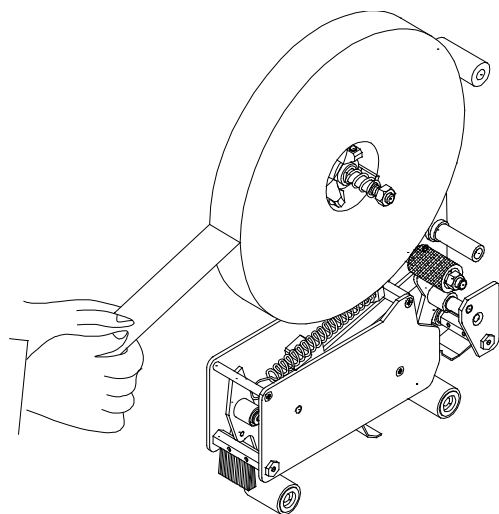

Check the tape for correct tension. Tighten or loosen the tape core holder to adjust tension.

Thread Tape

Carefully thread the new tape through the rollers in the tape head as shown in the applicable diagram in the Tape Head User Guide provided with the tape head.

For convenience, diagrams for threading tape in the Eastey-EX Tape Head and EZ-EX Tape Head are provided on the following page. Follow the diagram that applies for your tape head, depending on the tape head model and position on the taper.

Eastey-EX Tape Head

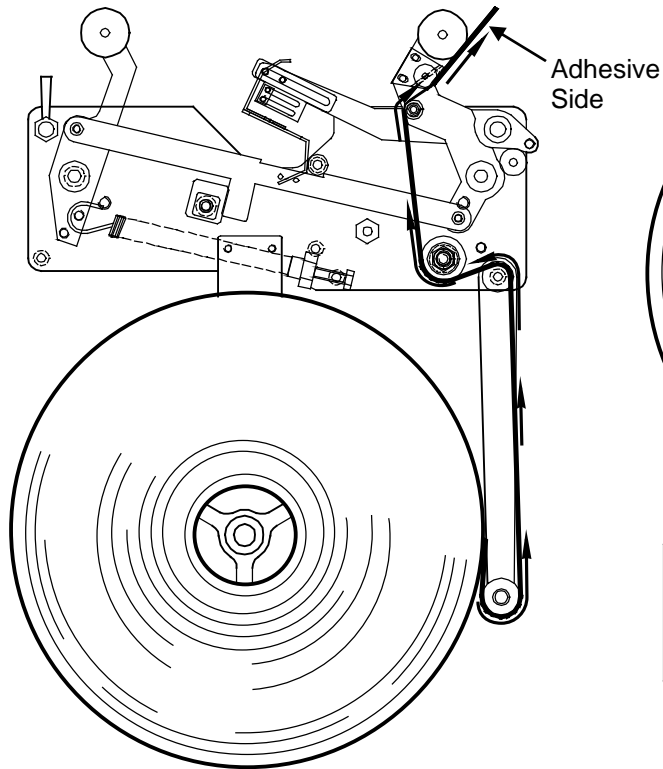

Bottom Cartridge

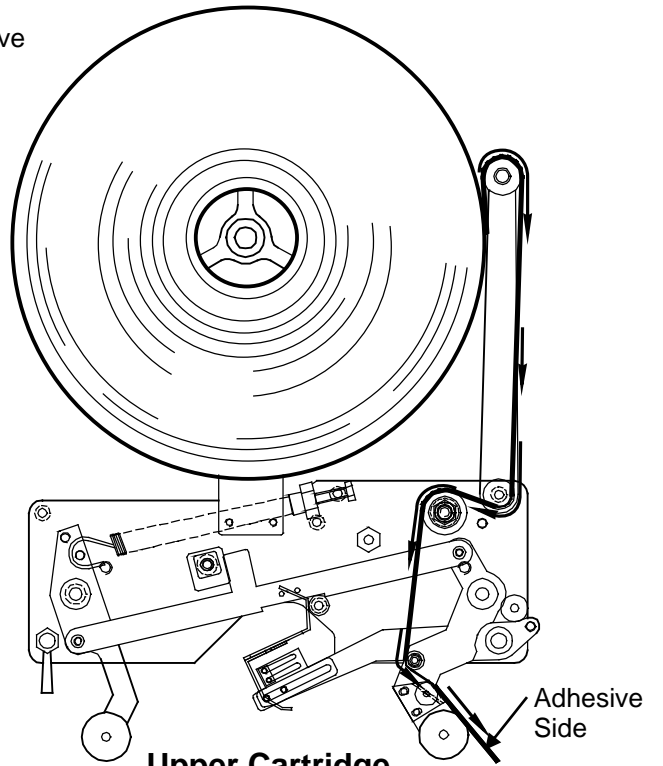

Upper Cartridge

EZ-EX Tape Head

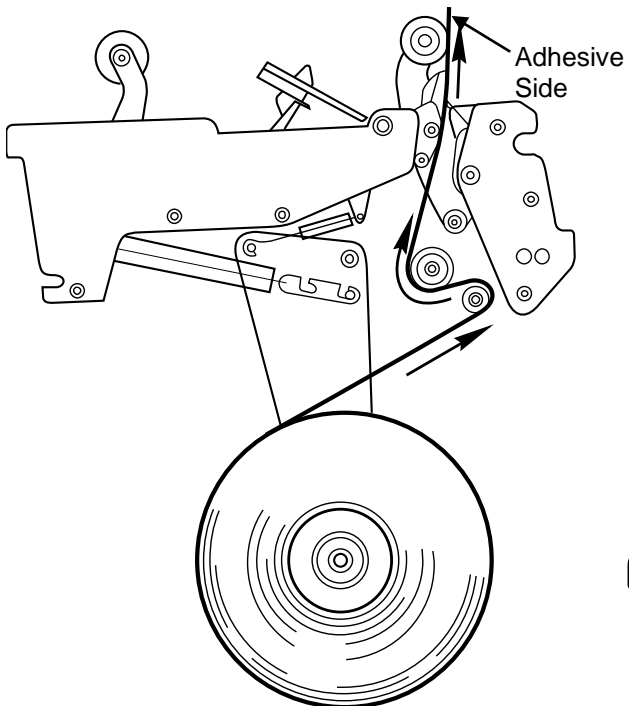

Bottom Cartridge

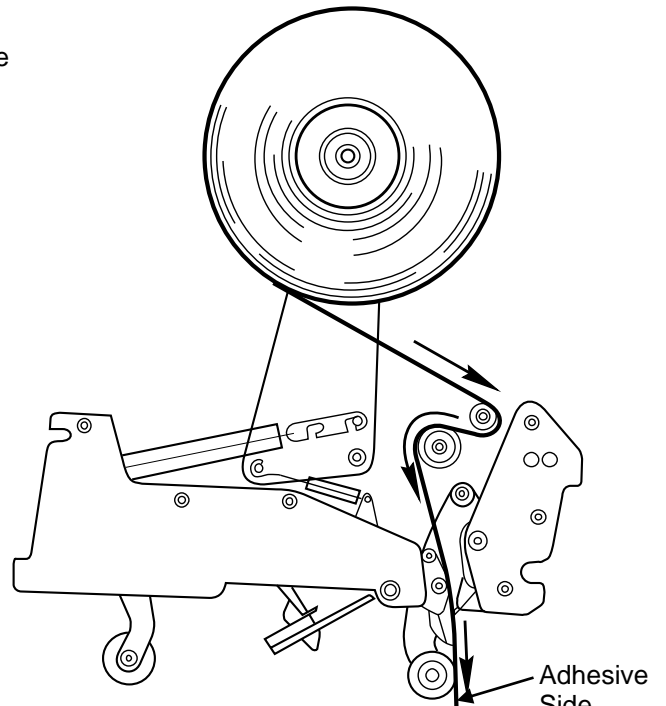

Upper Cartridge

Center Tape — Eastey-EX Tape Head only

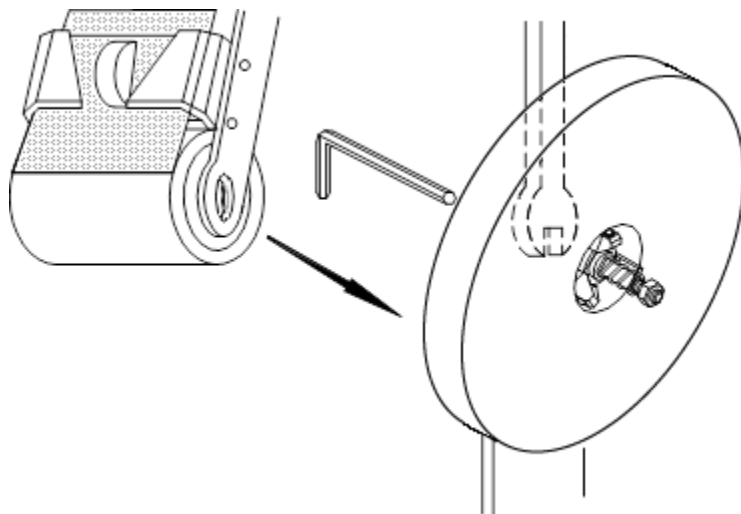

Make sure the tape is centered on all the rollers.

There are several rollers in the tape cartridge where the tape alignment should be checked to verify the tape stays on center as it is being dispensed.

Return the tape cartridge to the operation position.

Main Spring

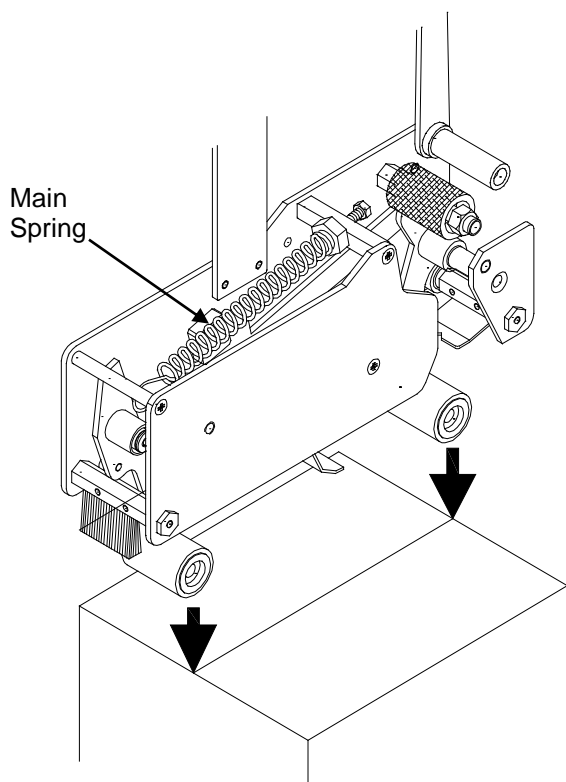

For sealing light weight boxes, decrease the main spring tension. For heavier boxes, increase the main spring tension.

When setting tension for the rollers, consider the amount of pressure on the box flaps required to make the seal. Cartons completely filled to the top with product may require more pressure on top and bottom seams when applying tape than partially-filled cartons, where excessive pressure could possibly crush the carton.

Power

Plug the power supply cord into a properly wired and grounded outlet.

Press start button.

CAUTION! When the power is turned on be aware of moving parts and belts

Control Panel

When the main power switch is in the "ON" position the power lamp should be illuminated.

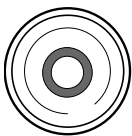
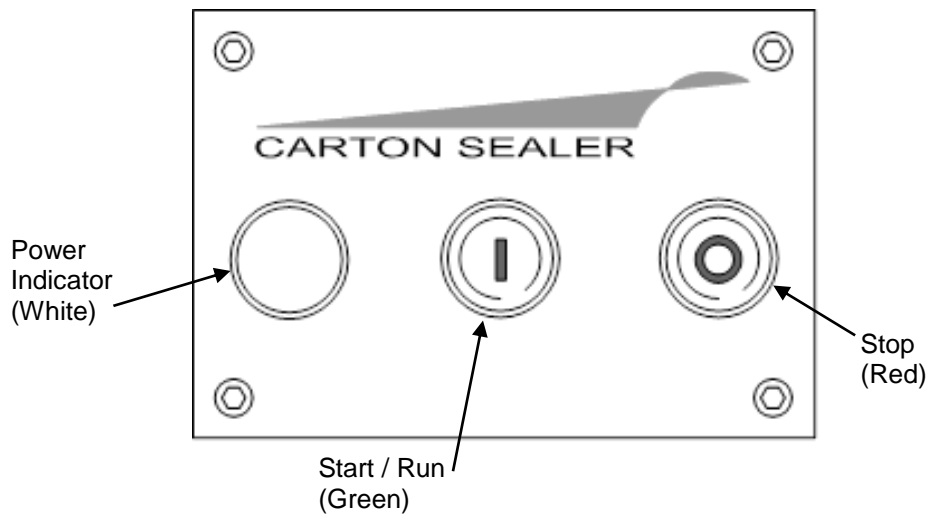

Stop Button (Red)
Press to stop motors and belts.



Start / Run Button (Green)
Press to start motors and belts.

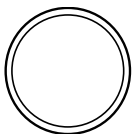

Power Indicator Lamp (White)
On when carton sealer is in operation.
Off when carton sealer is not in operation.

Emergency Stop

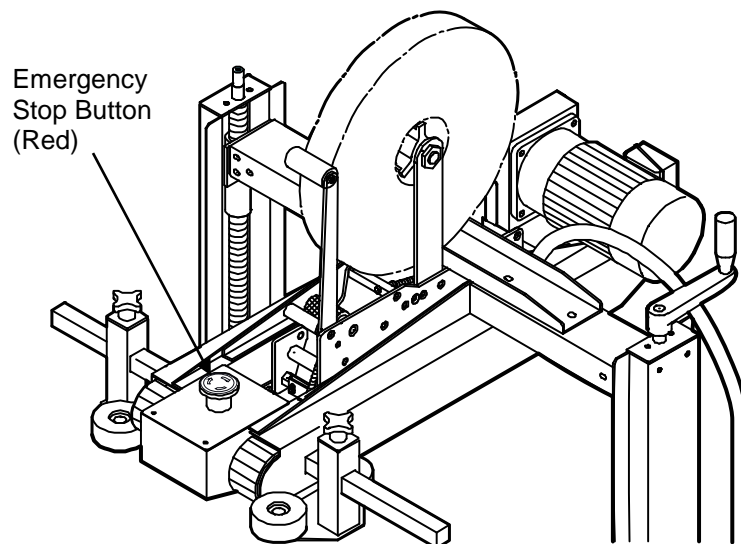

Emergency Stop Button (Red)

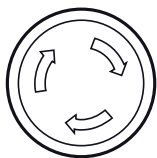

Press the button for emergency stop.

To reset the Emergency Stop button once the emergency condition has been cleared and it is safe to operate the machine again, press the Emergency Stop button in while turning it approximately a quarter-turn in the direction of arrows.

Adjustments

Carton Height and Width Adjustments

With the power off, place an appropriate size box filled with product in the Case Sealer. Position the box centered with the rollers, drive belts, and tape heads. Use the filled box to adjust the width of the side belts and squeezers, and height of the top tape head.

Side Belt Width Adjustment

Use the drive belt width adjustment crank to set the drive belt to the correct width for the box.

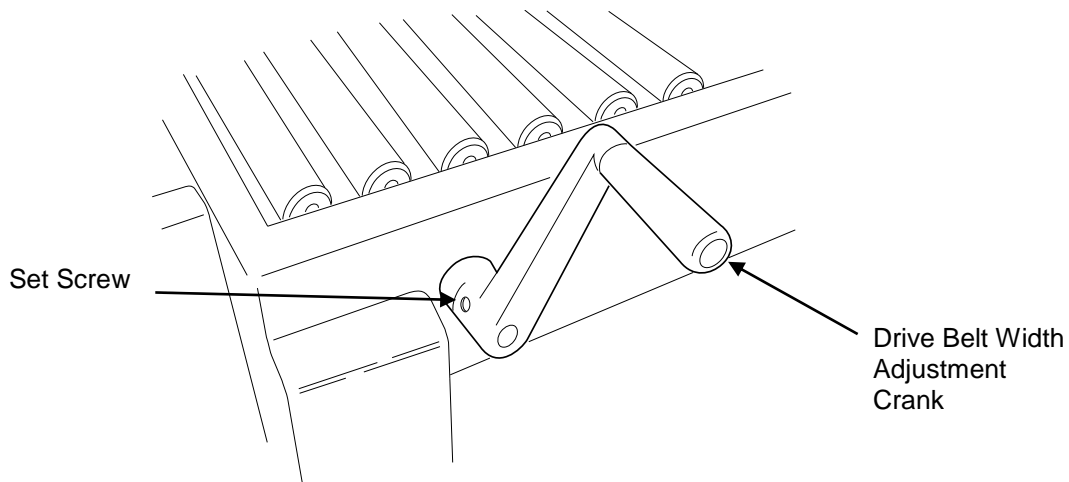

The side belt width adjustment crank can be mounted on either side of the machine by loosening the set screw, removing the crank, and mounting the crank on the opposite side of the machine. Re-tighten the set screw to secure the adjustment crank.

Upper Tape Head Height Adjustment

Use the height adjustment crank to set the upper tape head to the correct height for the box.

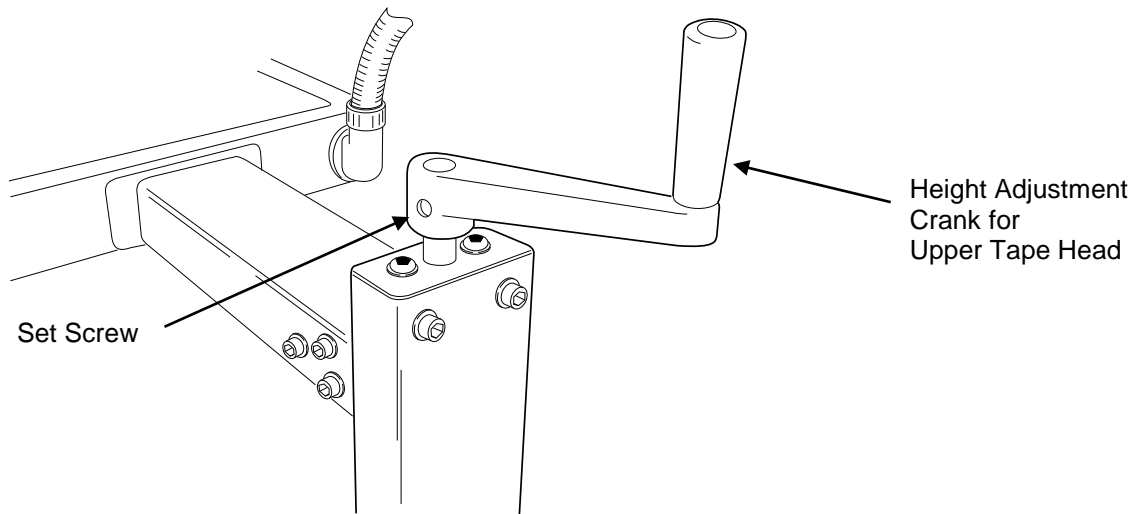

The height adjustment crank can be mounted on either side of the machine by loosening the set screw, removing the crank, and mounting the crank onto the adjustment spindle on the opposite side of the machine. Re-tighten the set screw to secure the adjustment crank.

Top Squeezer Adjustment

Loosen the locking knobs on the top squeezer alignment rollers to set the top width to the correct box width and re-tighten the locking knobs. This will insure the box stays centered.

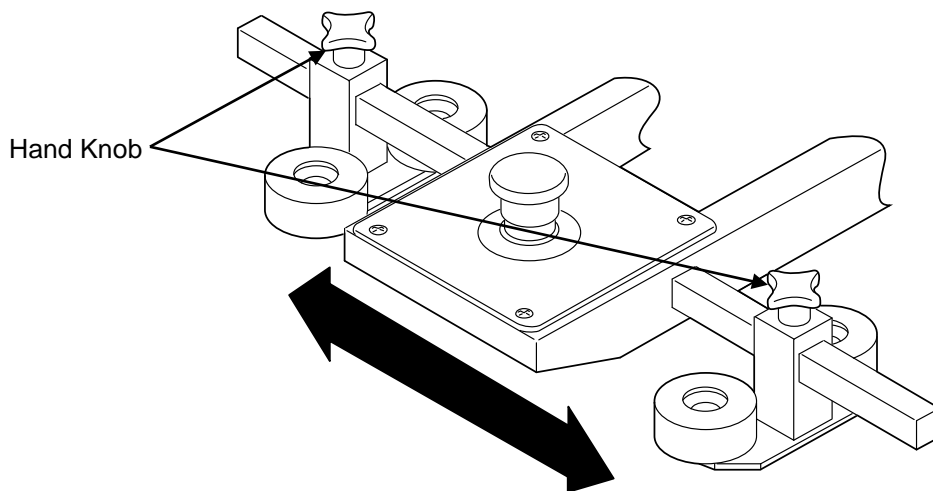

Belt Adjustment

You do not have to remove the drive belt cover to adjust the drive belt. To adjust the belt, use an Allen wrench and loosen the belt nut. Adjust the belt to a suitable tension by turning the adjustment screw with a Phillips screwdriver. Re-tighten the belt nut.

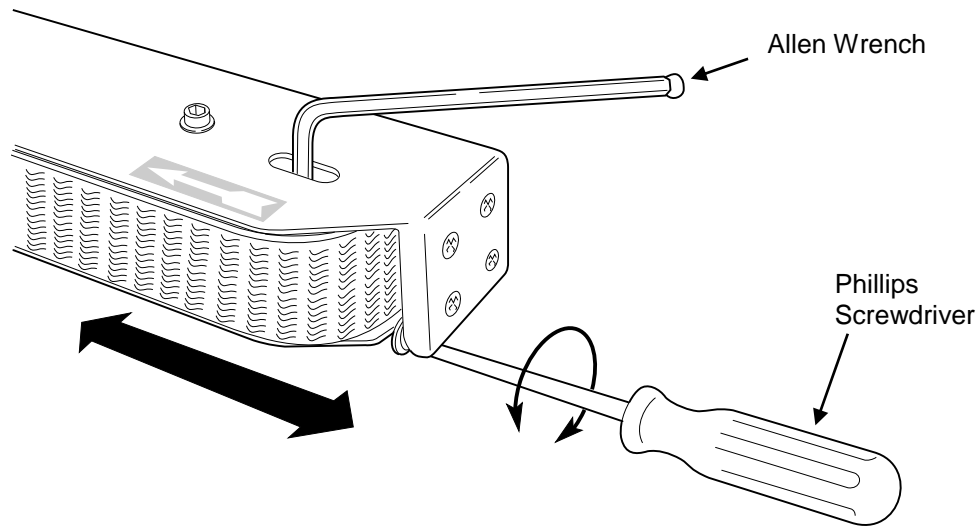

Machine Body Height Adjustment

To adjust the leg height, loosen the screws on each leg and slide the insert up or down. When the leg is at the desired height, retighten the adjustment screws to secure the leg height.

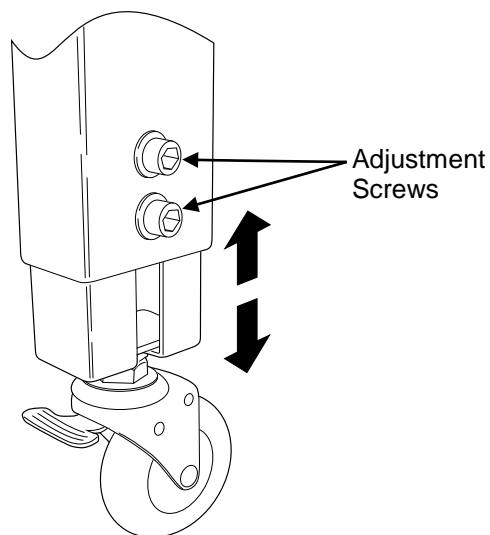

CAUTION! Ensure the case taper is secure and will not shift while adjusting leg height.

Tape Head Adjustment — Refer to Tape Head User Guide.

Refer to instructions in the Tape Head User Guide that is provided with the tape head for instructions regarding adjustment information for the tape head.

Maintenance

The SB-2/3EX Standard Industrial Case Taping System will provide many hours of maintenance free operation. There are a few items that may require attention from time to time.

Rollers

Make sure rollers stay clean and grease free. If you should have to clean the rollers simply wipe them down with a clean lint free cloth. If a more thorough cleaning is necessary wipe the rollers down with a mild detergent and water and let dry. **Never use harsh or abrasive cleaners or chemical agents when cleaning the rollers.**

Cutting Knives

Occasionally inspect the cutting knives to ensure they are clean and free of adhesive residue. Make sure the cutting knife is sharp by inspecting cuts in the tape. Cuts should be straight and neat. If the quality of cuts is eroding, the knife blade is dull and should be replaced.

Changing Knife Blades — Refer to Tape Head User Guide

Turn off and unplug the taper. It is not necessary to remove either tape head to change the blade. Refer to the Tape Head User Guide provided with the tape head for instructions for changing the knife blades.

CAUTION! Always be aware of the cutting edges while replacing the knife blades. Handle the knife blades carefully.

Troubleshooting

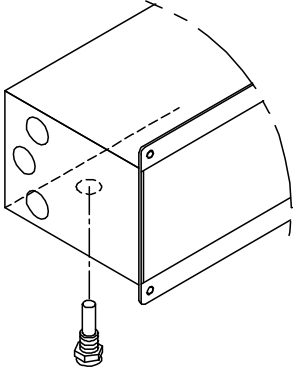
Problem	Solution
Taper will not start	<ul style="list-style-type: none"> • Check power input. • Release the Emergency Stop button. • Press the Start button to release overload. • Replace Fuse. (Access fuse by removing plug from underside of control box as shown at right.) 
Machine is not operating	<ul style="list-style-type: none"> • Machine has inadequate electrical power or power is not connected. Verify system power meets specification requirements. • An Emergency Stop condition exists. Clear the machine and reset the Emergency Stop.
Stuck carton	<ul style="list-style-type: none"> • Check drive belt width adjustment. • Check for proper height adjustment.
Uneven or poor tape cuts	<ul style="list-style-type: none"> • Adjust knife arm spring tension. • Adjust wipe roller spring tension. • Replace cutting knives.
Uneven Tape Leg on Front	<ul style="list-style-type: none"> • Tape tension is too low. Tighten the one-way clutch roller and/or the tape core. • Adjust the one-way clutch roller in the slot so it is slightly beyond the front wipe roller. • Adjust the tape leg length. See Tape Leg Adjustment section.

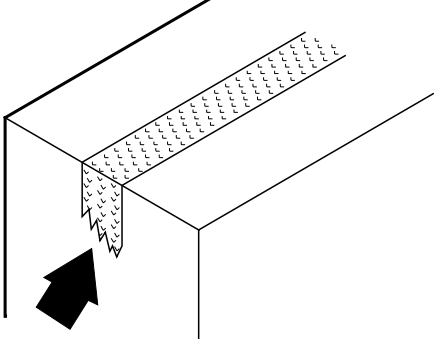
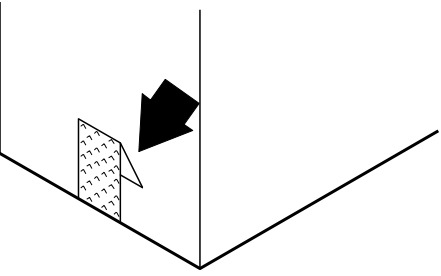
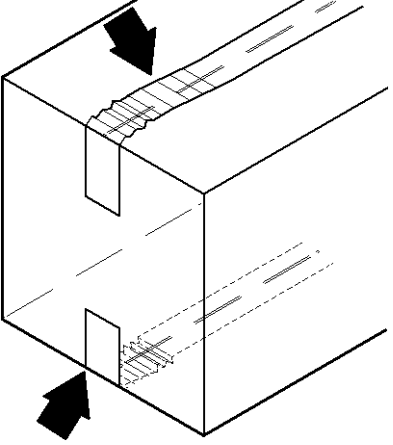
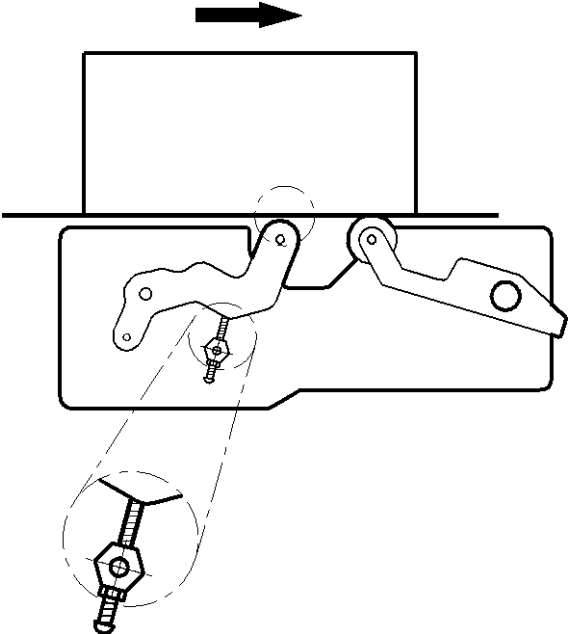
Problem	Solution
<p>Uneven or Torn Tape</p> 	<ul style="list-style-type: none"> • Blade is dull. Replace blade. • Tape tension is incorrect. Increase tension. • Clean and adjust blade. • Blade mounted incorrectly or backwards. • Knife arm spring is worn. Replace knife arm spring. • Adjust cartridge height.
<p>Tape Folding</p> 	<ul style="list-style-type: none"> • Check that all rollers turn freely. • Check to be sure tape is threaded properly on front roller (page 17). • Check wipe down brush.
<p>Tape Curling and Bunching Up — Eastey EX Tape Head Only</p> 	<p>Eastey-EX Tape Head Only</p> <ul style="list-style-type: none"> • Adjust the tape cartridge height (approximately .06 inches from box)  <ul style="list-style-type: none"> • Check tape tension set by the spring tension at the tape core.

Parts List

Electrical

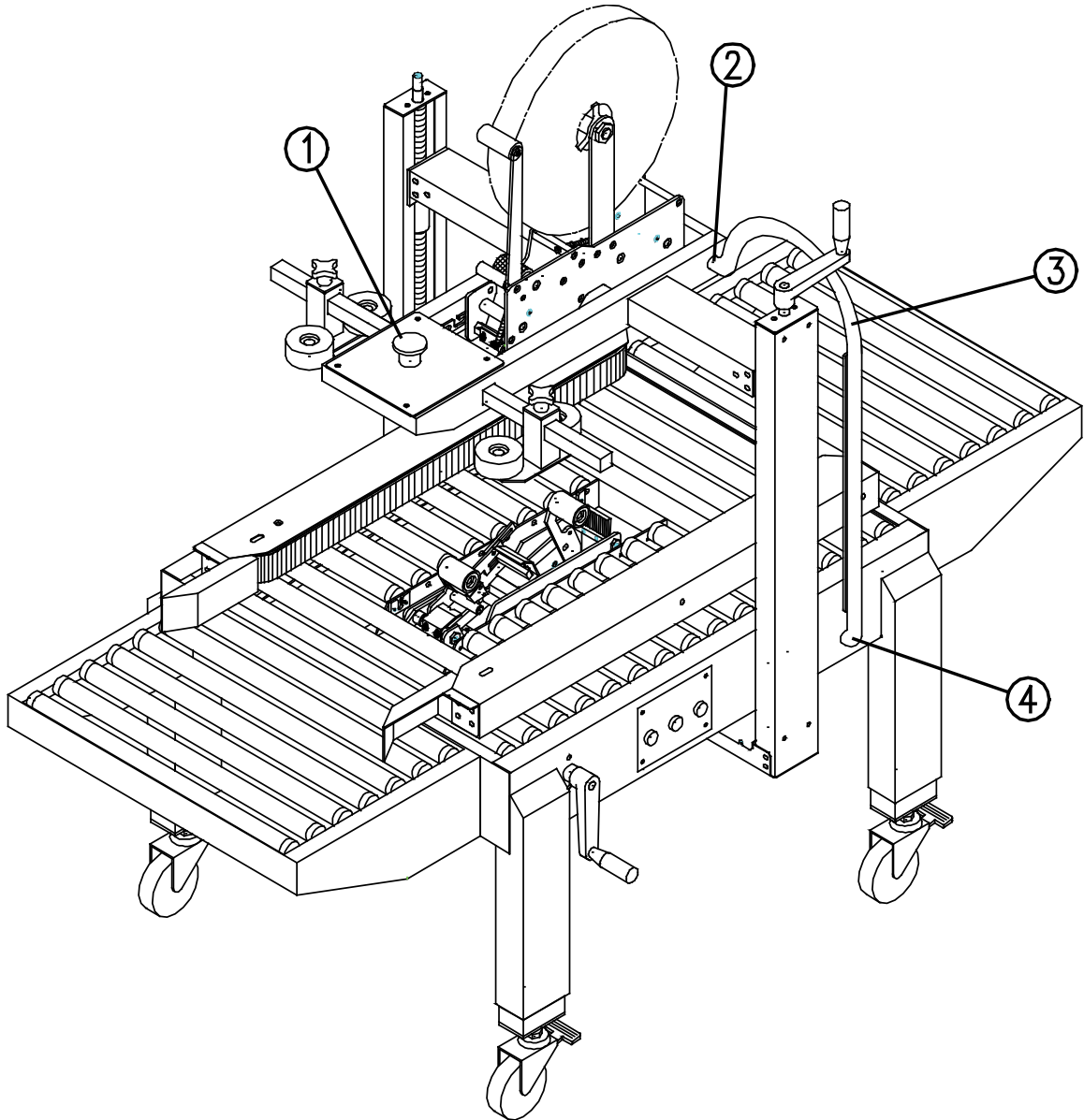

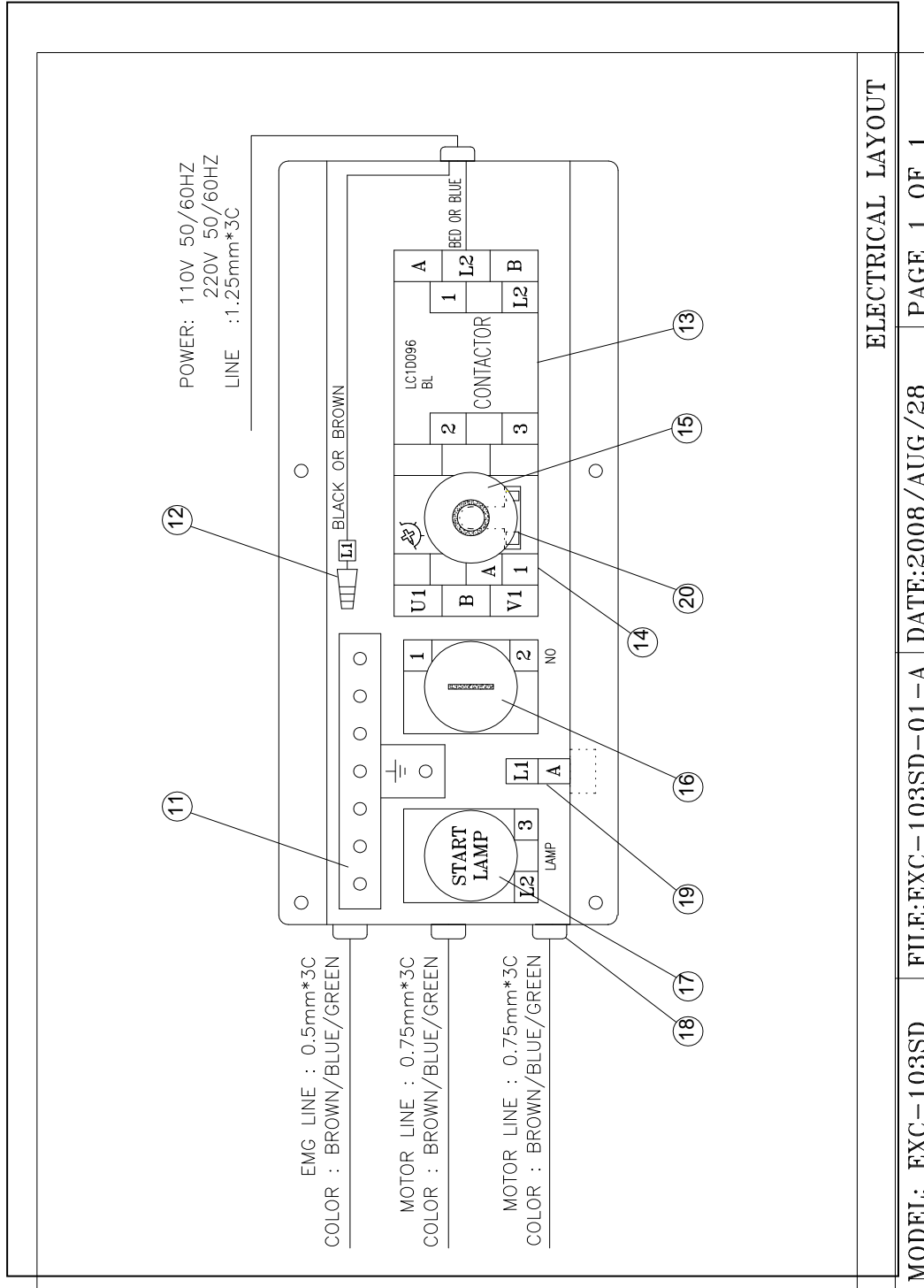

Electrical Layout

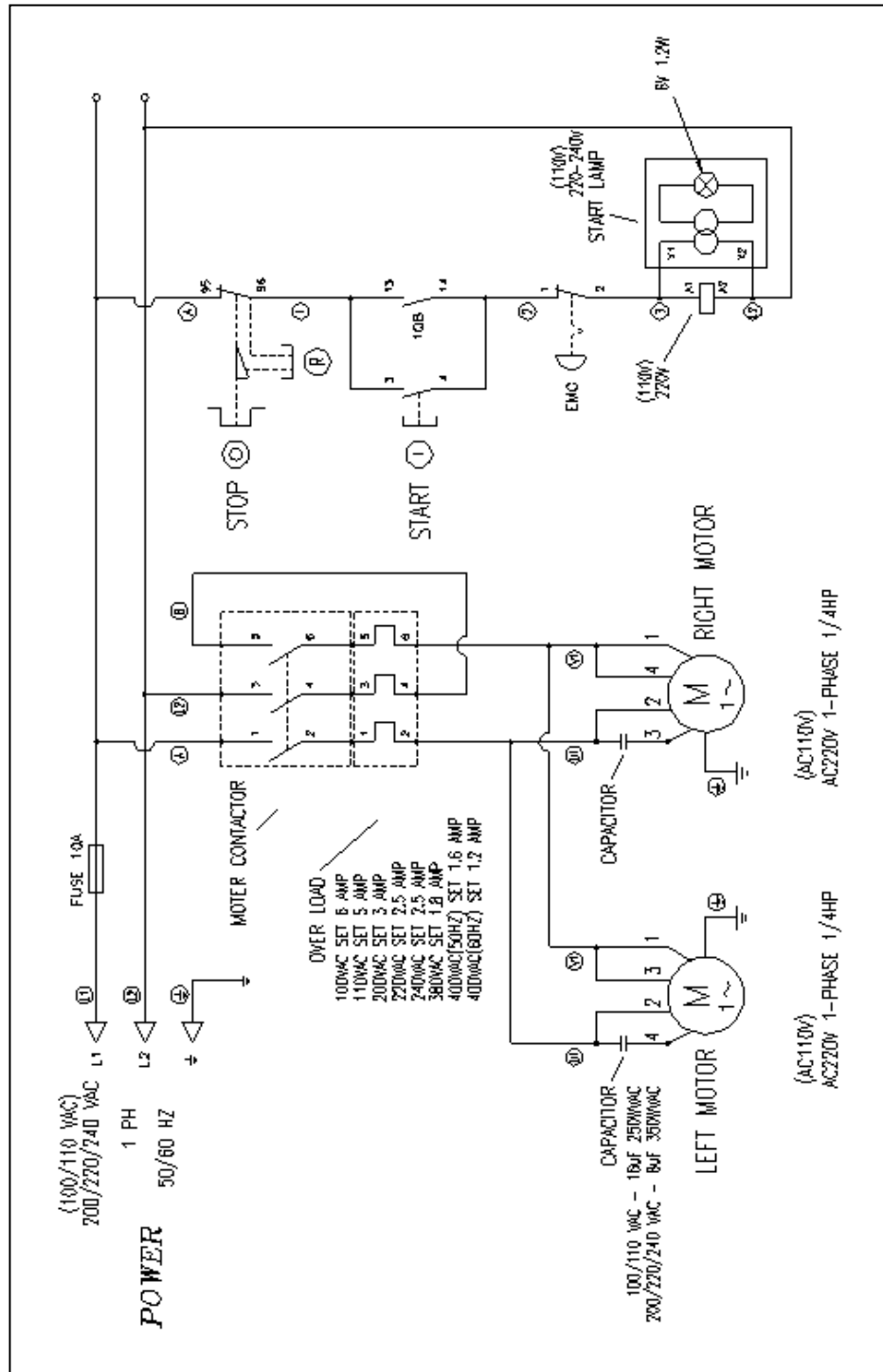

Electrical Layout Cont.

KEY NO	PART NO.	DESCRIPTION	Q'TY
1	7155BC20	EMG. SWITCH	1
	7158BZ12	BUTTON SEAT CONTACTOR NCx1	1
2	7066P001	1/2" CONNECTOR	1
3	7065C062	1/2" PROTECT TUBE	1
4	7066C064-1	1/2" 90° CONNECTOR	1
11	70560601	TERMINAL BLOCKS TB6P	1
12	7032SW01	CONNECTOR	1
13	71570002-01	BREAKER LC1-D09F7 110V	1
	71570003-01	BREAKER LC1-D09M7 220V	1
14	71570002-02	OVERLOAD PROTECTOR LR3-D106(4-6A)(110V)	1
	71570003-02	OVERLOAD PROTECTOR LR3-D086(2.5-4A)(220V)	1
15	7155AL01	BUTTON	1
16	7155AA03	BUTTON	1
	7158AZ01	CONTACTOR NOX1	1
17	7151AV01	POWER LAMP 220V	1
	7150AV01	BLANKIG PLUG	1
	7151AV02	POWER LAMP 110V	1
	7150AV01	BLANKIG PLUG	1
18	7025AG16	FIXED SEAT	4
19	72561003	FUSE	1
	7250FH01	FUSE SEAT	1
20	7155AL01-1	ENCLOSURE	1

Side Belt Assembly

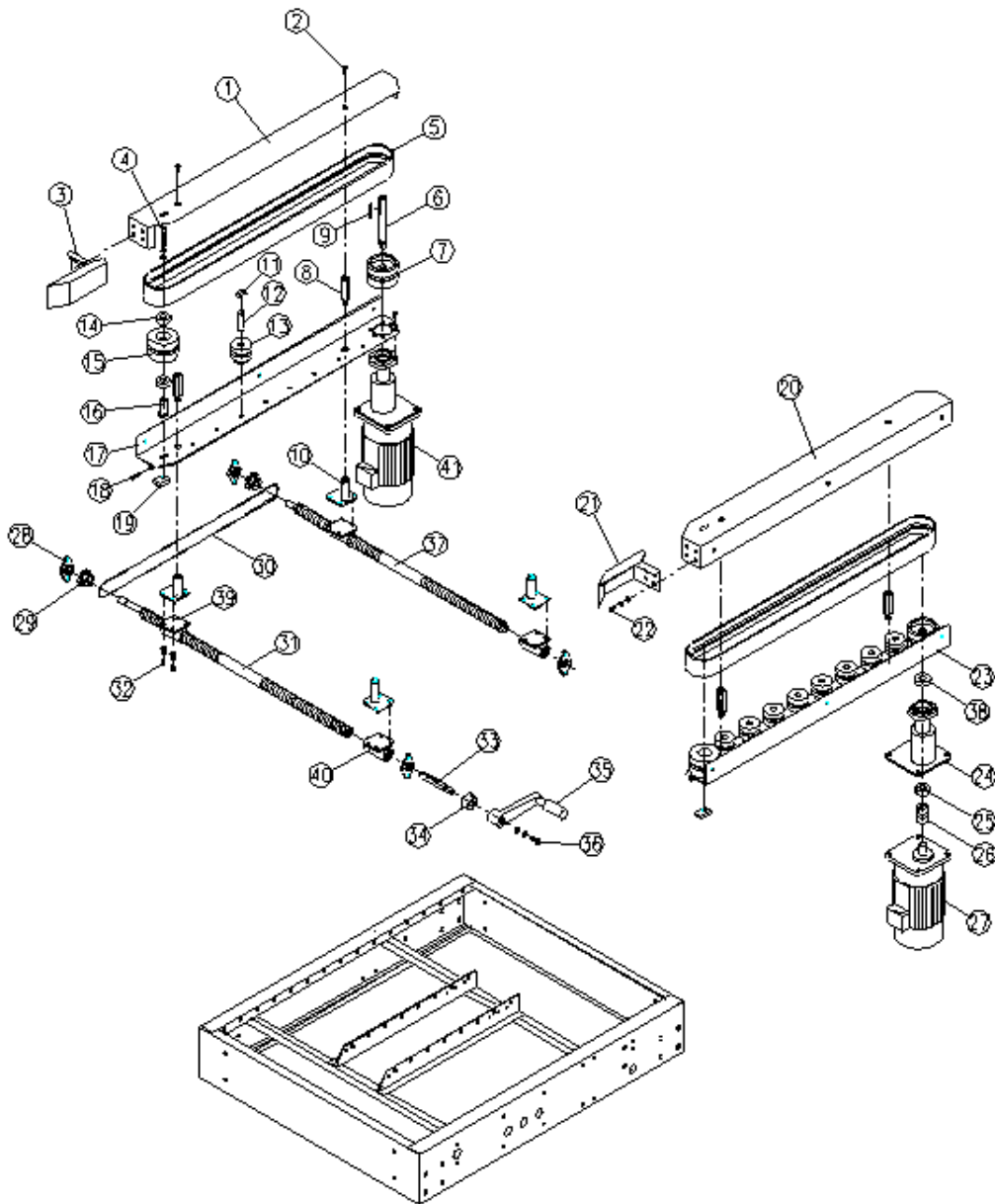

KEY NO	PART NO.	DESCRIPTION	Q'TY
1	CA3006L0	SIDE BELT COVER	1
2	10170610	SCREW M6*10L & S.W & W	4
3	CA3010L0	GUIDE PLATE	1
4	10100870	SCREW M8*70L & W	2
5	CA302700	BELT	2
6	CA30250A	MOTOR SHAFT	2
7	CA301900	PULLEY DRIVER	2
8	CA301700	SPEDIAL SCREW	4
9	10925300	KEY 5*5	2
10	CA301600	SUPPORT SHAFT	4
11	11301200	RING STW-12	16
12	CA301400	PULLEY SHAFT	16
13	CA301300	PLASTIC PULLEY	16
14	30300030	BEARING 6003ZZ	4
15	CA301100	PULLEY FOLLOWER	2
16	CA301200	PULLEY SHAFT	2
17	CA3005L0	SUPPORT COLUMN	1
18	10130545	SCREW M5*45L	2
19	CA301800	ADJUSTMLNT BLOCK	2
20	CA3006R0	SIDE BELT COVER	1
21	CA3010R0	GUIDE PLATE	1
22	10100612	SCREW M6*12L & S.W & W	8
23	CA3005R0	SUPPORT COLUMN	1
24	CA302900	MOTOR SEAT	2
25	30300030	BEARING 6003ZZ	2
26	CA303000	UNIVERSAL JOINT	2
27	745111R1	MOTOR 110V/60HZ,T18:1	1
	745122R1	MOTOR 220V/60HZ,T18:1	1
	745122R2	MOTOR 220V/50HZ,T15:1	1
	745124R2	MOTOR 240V/50HZ,T15:1	1
	745138R1	MOTOR 380V/50HZ,T15:1	1
	745140R1	MOTOR 400V/50HZ,T15:1	1
28	CA302000	SHAFT SEAT	4

29	CA302200	CHAIN SPPOCKET	2
30	3240S355	CHAIN	1
31	CA300700	SPINDLE WIDTH ADJUSTMENT	1
32	10100612	SCREW M6*12L & S.W & W	8
33	CA300900	SHAFT	1
34	CA303200	HANDLE RING	2
35	CA201500	HANDLE CRANKK ARM	1
36	10100620	SCREW M6*20L & S.W & W	1
37	CA300800	SPINDLE WIDTH ADJUSTMENT	1
38	30302031	BEARING 6203ZZ	2
39	CA3015R0	SPINDLE SUPPORT	2
40	CA3015L0	SPINDLE SUPPORT	2
41	745111L1	MOTOR 110V/60HZ,T18:1	1
	745122L1	MOTOR 220V/60HZ,T18:1	1
	745122L2	MOTOR 220V/50HZ,T15:1	1
	745124L2	MOTOR 240V/50HZ,T15:1	1
	745138L1	MOTOR 380V/50HZ,T15:1	1
	745140L1	MOTOR 400V/50HZ,T15:1	1

Side Belt Assembly (Stainless)

KEY NO	PART NO.	DESCRIPTION	Q'TY
1	KA111138L0-S	SIDE BELT COVER	1
2	10170610S	SCREW M6*10L & S.W & W	4
3	CA3010L0	GUIDE PLATE	1
4	10100870S	SCREW M8*70L & W	2
5	CA302700	BELT	2
6	CA30250A-S	MOTOR SHAFT	2
7	CA301900	PULLEY DRIVER	2
8	CA301700-S	SPEDIAL SCREW	4
9	10925300	KEY 5*5	2
10	CA301600-S	SUPPORT SHAFT	4
11	11301200S	RING STW-12	16
12	CA301400-S	PULLEY SHAFT	16
13	CA301300	PLASTIC PULLEY	16
14	30300030-S	BEARING 6003ZZ	4
15	CA301100	PULLEY FOLLOWER	2
16	CA301200-S	PULLEY SHAFT	2
17	CA3005L0-S	SUPPORT COLUMN	1
18	10130545S	SCREW M5*45L	2
19	CA301800-S	ADJUSTMLNT BLOCK	2
20	KA111138R0-S	SIDE BELT COVER	1
21	CA3010R0	GUIDE PLATE	1
22	10100612S	SCREW M6*12L & S.W & W	8
23	CA3005R0-S	SUPPORT COLUMN	1
24	CA302900-S	MOTOR SEAT	2
25	30300030-S	BEARING 6003ZZ	2
26	CA303000	UNIVERSAL JOINT	2

27	745111R4	MOTOR 110V/60HZ,T18:1	1
	745122R4	MOTOR 220V/50HZ,T15:1	1
	745124R3	MOTOR 240V/50HZ,T15:1	1
	745138R3	MOTOR 380V/50HZ,T15:1	1
	745140R3	MOTOR 400V/50HZ,T15:1	1
28	CA302000-S	SHAFT SEAT	4
29	CA3022S0	CHAIN SPPOCKET	2
30	3240S355-S	CHAIN	1
31	CA300700-S	SPINDLE WIDTH ADJUSTMENT	1
33	CA300900-S	SHAFT	1
34	CA303200	HANDLE RING	2
35	CA201500	HANDLE CRANK ARM	1
36	10100620S	SCREW M6*20L & S.W & W	1
37	CA300800-S	SPINDLE WIDTH ADJUSTMENT	1
38	30302031-S	BEARING 6203ZZ	2
39	CA3015R0-S	SPINDLE SUPPORT	2
40	CA3015L0-S	SPINDLE SUPPORT	2
41	745111L4	MOTOR 110V/60HZ,T18:1	1
	745122L4	MOTOR 220V/50HZ,T15:1	1
	745124L3	MOTOR 240V/50HZ,T15:1	1
	745138L3	MOTOR 380V/50HZ,T15:1	1
	745140L3	MOTOR 400V/50HZ,T15:1	1

Vertical Column

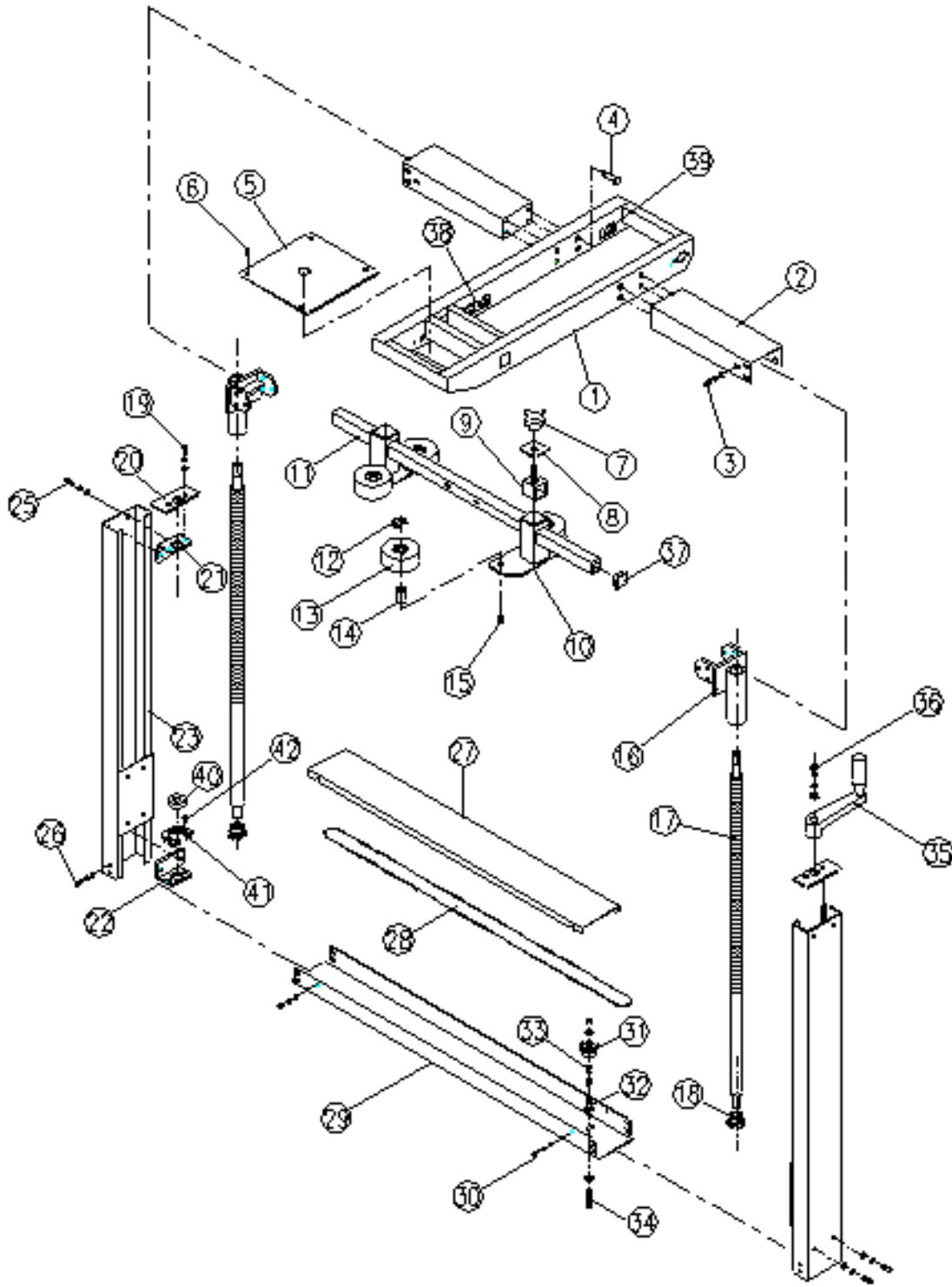

KEY NO	PART NO.	DESCRIPTION	Q'TY
1	CA10010A	TAPING SET SUPPORT	1
2	CA10110A	SUPPORT SET	2
3	10100612	SCREW M6*12L & S.W & W	12
4	CA101500	LINING	8
5	CA10040A	COVER PLATE	1
6	10140406	SCREW M4*6L	4
7	CA101600	HANDLE KNOB	2
8	CA100900	LOCKING BRACKET	2
9	CA100800	SCREW KNOB	2
10	CA100500	COMPRESSION ROLLER SEAT	2
11	CA101000	SUPPORT BAR	1
12	11301700	RING STW-17	4
13	CA100600	COMPRESSION ROLLER	4
14	CA100700	COMPRESSION ROLLER SHAFT	4
15	10140610	SCREW M6*10L	4
16	CA200900	SPINDLE SUPPORT	2
17	CA200700	HEIGHT ADJUSTMENT SPINDLE	2
18	CA200800	CHAIN WHEEL	2
19	10100612	SCREW M6*12L & S.W & W	4
20	CA20040A	COVER PLATE	2
21	CA200200	SET PLATE	2
22	CA200300	SET PLATE	2
23	CA20010A	COLUMN	2
25	10100612	SCREW M6*12L & S.W & W	8
26	10100612	SCREW M6*12L & S.W & W	8
27	CA201200	CHAIN PLATE	1
28	3240S356	CHAIN	1
29	CA201100	CHAIN COVER	1
30	10190410	SCREW M4*10L & S.W & W	4
31	CA201600	CHAIN WHEEL	1
32	CA201700	CHAIN WHEEL SHAFT	1
33	CT212100	BUSH Ø10 x Ø12 x 10L	2

40 Illustrated Parts List

34	10100635	SCREW M6*35L & S.W & NUT	1
35	CA201500	HANDLE CRANKK ARM	1
36	10170816	SCREW M8*16L & S.W & W	1
37	91350001	RUBBER PLUG	2
38	CA100300	B-PLATE	2
39	CA100200	A-PLATE	2
40	30302020	BEARING 6202ZZ	2
41	CA304500	BEARING SEAT	2
42	10140616	SCREW M6*16L	4

Vertical Column (Stainless)

KEY NO	PART NO.	DESCRIPTION	Q'TY
1	CA10010B -S	TAPING SET SUPPO RT	1
2	CA10110A-S	SUPPORT SET	2
3	10100612S	SCREW M6*12L & S.W & W	12
4	CA101500-S	LINING	8
5	CA10040A-S	COVER PLATE	1
6	10140406S	SCREW M4*6L	4
7	CA101600	HANDLE KNOB	2
8	CA100900-S	LOCKING BRACKET	2
9	CA100800-S	SCREW KNOB	2
10	CA100500	COMPRESSION ROLLER SEAT	2
11	CA101000-S	SUPPORT BAR	1
12	11301700	RING STW-17	4
13	CA100600	COMPRESSION ROLLER	4
14	CA100700-S	COMPRESSION ROLLER SHAFT	4
15	10140610S	SCREW M6*10L	4
16	CA200900-S	SPINDLE SUPPORT	2
17	CA200700-S	HEIGHT ADJUSTMENT SPINDLE	2
18	CA2008S0	CHAIN WHEEL	2
19	10100612S	SCREW M6*12L & S.W & W	4
20	CA20040A-S	COVER PLATE	2
21	CA200200-S	SET PLATE	2
22	CA200300-S	SET PLATE	2
23	CA20010A-S	COLUMN	2
25	10100612S	SCREW M6*12L & S.W & W	8
26	10100612S	SCREW M6*12L & S.W & W	8
27	CA201200-S	CHAIN PLATE	1

42 Illustrated Parts List

28	3240S356-S	CHAIN	1
29	CA201100-S	CHAIN COVER	1
30	10190410S	SCREW M4*10L & S.W & W	4
31	CA201600-S	CHAIN WHEEL	1
32	CA201700-S	CHAIN WHEEL SHAFT	1
33	CT212100	BUSH Ø10 x Ø12 x 10L	2
34	10100635S	SCREW M6*35L & S.W & NUT	1
35	CA201500	HANDLE CRANK ARM	1
36	10170816S	SCREW M8*16L & S.W & W	1
37	91350001	RUBBER PLUG	2
40	30302020-S	BEARING 6202ZZ	2
41	CA304500	BEARING SEAT	2
42	10140616S	SCREW M6*16L	4

Machine Body

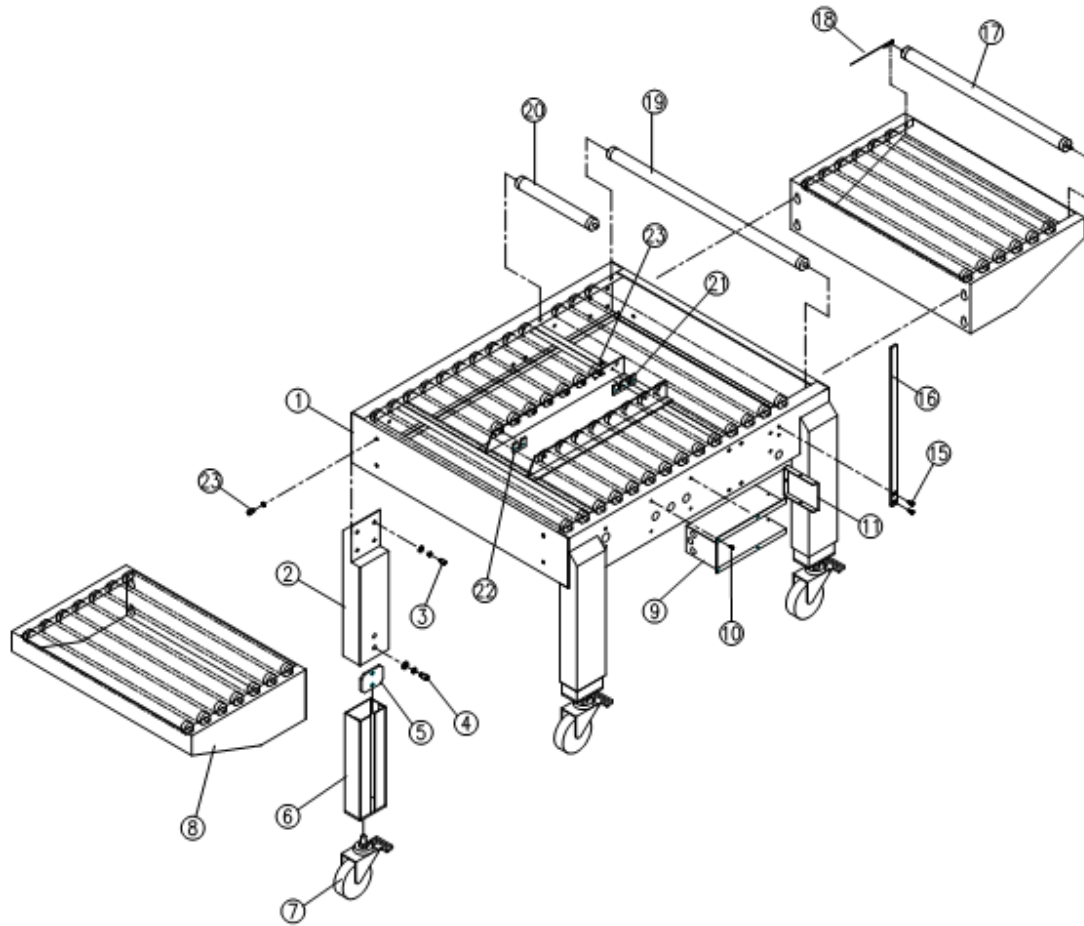

KEY NO	PART NO.	DESCRIPTION	Q'TY
1	CA30010A	MACHINE FRAME	1
2	CA300200	MACHINE LEG	4
3	10100816	SCREW M8*16L & S.W & W	16
4	10101016	SCREW M10*16L & S.W & W	8
5	CA30040A	CLAMP	4
6	CA30030A	ADJUSTABLE LEG	4
7	9201L501	CASTER	4
8	CA400100	ROLLER SEAT	2
9	CA30280A	ELECTRICAL BOX	1
10	10170510	SCREW M5*10L	4
11	CA304300	ELECTRICAL COVER	1
15	10140612	SCREW M6*12L	2
16	CA101400	FIXED SEAT	1
17	CA400200	ROLLER	14
18	10750001	PIN	26
19	CA302400	ROLLER(LONG)	7
20	CA302300	ROLLER(SHORT)	16
21	CA33070A	B-PLATE	2
22	CA33060A	A-PLATE	2
23	10100812	SCREW M8*12L & S.W & W	8

Machine Body (Stainless)

KEY NO	PART NO.	DESCRIPTION	Q'TY
1	CA30010A-S	MACHINE FRAME	1
2	CA300200-S	MACHINE LEG	4
3	10100816S	SCREW M8*16L & S.W & W	16
4	10101016S	SCREW M10*16L & S.W & W	8
5	CA30040A-S	CLAMP	4
6	CA30030A-S	ADJUSTABLE LEG	4
7	9201L501-S	CASTER	4
8	CA400100-S	ROLLER SEAT	2
9	CA30280A-S	ELECTRICAL BOX	1
10	10170510S	SCREW M5*10L	4
11	CA304300-S	ELECTRICAL COVER	1
15	10140612S	SCREW M6*12L	2
16	CA101400-S	FIXED SEAT	1
17	CA400200-S	ROLLER	14
18	10750001-S	PIN	26
19	CA302400-S	ROLLER(LONG)	7
20	CA302300-S	ROLLER(SHORT)	16
21	CA33070A-S	B-PLATE	2
22	CA33060A-S	A-PLATE	2
23	10100812S	SCREW M8*12L & S.W & W	8

Tape Head (2" or 3") — Refer to Tape Head User Guide

Refer to the User Guide provided with the Tape Head for the Illustrated Parts List and part numbers for Tape Head parts.

Warranty Statement

SB-2/3EX Standard Carton Sealing Machine

Warranty Statement

Eastey Enterprises warrants that all of the products it ships will be in good working order and free from defects in material and workmanship and will conform to the published specifications for that product.

Warranty Period

Drive motor(s):	1 year
Gear reducer:	1 year
Tapehead:	1 year (Except for moving parts which are subject to normal wear, tear and replacement which are warranted to be free from defects in material and workmanship.)
All other parts:	1 year (Except for moving parts which are subject to normal wear, tear and replacement which are warranted to be free from defects in material and workmanship.)

Taping Quality

Taping quality achieved in a given application is dependent on the installation, the material handling, and the maintenance provided. Eastey makes no warranty that the taping quality achieved in an application will be the same as that achieved on a test piece in our demo facility.

Shipping Policy

Customer pays all incoming shipping. If the item is defective and under warranty, Eastey pays return shipping charges for least costly method. If expedited shipping is desired, customer must furnish his shipping account and shipping fees will be charged to that account.

Warranty Verification

If you conclude that a product may be defective and may be covered by warranty, obtain a Return Material Authorization number by calling our technical support number (toll free at 1-800-835-9344, or 763-428-4846 or Fax: 763-795-8867) or e-mail: info@eastey.com, and return the defective item to Eastey. Eastey will analyze the product and, if found to be defective, we will, at our option, replace or repair the item. If the item is found to not be eligible for warranty, you will be notified and may decide on disposition. Defective products will be replaced or repaired as promptly as possible.

Warranty Eligibility

The warranty provided by Eastey Enterprises. is only to the original buyer.

Limited Warranty

THE ABOVE WARRANTY IS EXCLUSIVE AND IN LIEU OF ALL OTHER WARRANTIES, WHETHER EXPRESSED OR IMPLIED, INCLUDING THE IMPLIED WARRANTIES OF MERCHANTABILITY, FITNESS FOR A PARTICULAR PURPOSE AND NONINFRINGEMENT.

Disclaimer of Damages

REGARDLESS OF WHETHER ANY REMEDY SET FORTH HEREIN FAILS OF ITS ESSENTIAL PURPOSE, IN NO EVENT WILL EASTEY ENTERPRISES, INC. BE LIABLE FOR ANY SPECIAL, CONSEQUENTIAL, INDIRECT OR SIMILAR DAMAGES, INCLUDING LOST PROFIT OR LOST OPPORTUNITIES OF ANY TYPE ARISING OUT OF THE USE OR INABILITY TO USE THESE PRODUCTS EVEN IF EASTEY ENTERPRISES, INC. HAS BEEN ADVISED OF THE POSSIBILITY OF SUCH DAMAGES.

Customer Support

Eastey Technical Service

For help setting up or operating the SB-2/3EX Standard Case Taper, please contact Eastey Technical Service at one of the numbers listed below.

Toll-Free Phone	800-835-9344
Phone	763-428-4846
Fax	763-795-8867
E-mail	info@eastey.com
Web	www.eastey.com

Thanks again for your purchase of Eastey products. We are pleased to be a part of your packaging needs.

update LTD

www.updateltd.com

1-800-229-0009

EASTLEY®